



# **ST. ANNE'S COLLEGE OF ENGINEERING AND TECHNOLOGY**

Approved by AICTE, New Delhi. Affiliated to Anna University, Chennai

Accredited by NAAC

ANGUCHETTYPALAYAM, PANRUTI – 607 106.

## **DEPARTMENT OF ELECTRICAL AND ELECTRONICS ENGINEERING**

### **EE 3301 - ELECTROMAGNETIC FIELDS**

**III SEMESTER**

Prepared by

Mrs. J. Arul Martinal, AP/EEE

**Electromagnetic theory** is a discipline concerned with the study of charges at rest and in motion. Electromagnetic principles are fundamental to the study of electrical engineering and physics. Electromagnetic theory is also indispensable to the understanding, analysis and design of various electrical, electromechanical and electronic systems. Some of the branches of study where electromagnetic principles find application are:

RF communication, Microwave Engineering, Antennas, Electrical Machines, Satellite Communication, Atomic and nuclear research, Radar Technology, Remote sensing, EMI EMC, Quantum Electronics, VLSI ,

Electromagnetic theory is a prerequisite for a wide spectrum of studies in the field of Electrical Sciences and Physics. Electromagnetic theory can be thought of as generalization of circuit theory. There are certain situations that can be handled exclusively in terms of field theory. In electromagnetic theory, the quantities involved can be categorized as **source quantities** and **field quantities**. Source of electromagnetic field is electric charges: either at rest or in motion. However an electromagnetic field may cause a redistribution of charges that in turn change the field and hence the separation of cause and effect is not always visible.

### *Sources of EMF:*

- Current carrying conductors.
- Mobile phones.
- Microwave oven.
- Computer and Television screen.
- High voltage Power lines.

### *Effects of Electromagnetic fields:*

- Plants and Animals.
- Humans.
- Electrical components.

### *Fields are classified as*

- Scalar field
- Vector field.

Electric charge is a fundamental property of matter. Charge exist only in positive or negative integral multiple of **electronic charge**,  $-e$ ,  $e = 1.60 \times 10^{-19}$  coulombs. [It may be noted here that in 1962, Murray Gell-Mann hypothesized **Quarks** as the basic building blocks of matters. Quarks were predicted to carry a fraction of electronic charge and the existence of Quarks have been experimentally verified.] Principle of conservation of charge states that the total charge (algebraic sum of positive and negative charges) of an isolated system remains unchanged, though the charges may redistribute under the influence of electric field. Kirchoff's Current Law (KCL) is an assertion of the

---

conservative property of charges under the implicit assumption that there is no accumulation of charge at the junction.

Electromagnetic theory deals directly with the electric and magnetic field vectors where as circuit theory deals with the voltages and currents. Voltages and currents are integrated effects of electric and magnetic fields respectively. Electromagnetic field problems involve three space variables along with the time variable and hence the solution tends to become correspondingly complex. Vector analysis is a mathematical tool with which electromagnetic concepts are more conveniently expressed and best comprehended. Since use of vector analysis in the study of electromagnetic field theory results in real economy of time and thought, we first introduce the concept of vector analysis.

### Vector Analysis:

The quantities that we deal in electromagnetic theory may be either **scalar** or **vectors** [There are other class of physical quantities called **Tensors**: where magnitude and direction vary with co ordinate axes]. Scalars are quantities characterized by magnitude only and algebraic sign. A quantity that has direction as well as magnitude is called a vector. Both scalar and vector quantities are function of *time* and *position*. A field is a function that specifies a particular quantity everywhere in a region. Depending upon the nature of the quantity under consideration, the field may be a vector or a scalar field. Example of scalar field is the electric potential in a region while electric or magnetic fields at any point is the example of vector field.

A vector  $\vec{A}$  can be written as,  $\vec{A} = \hat{a} A$ , where,  $A = |\vec{A}|$  is the magnitude and  $\hat{a} = \frac{\vec{A}}{|\vec{A}|}$  is the unit vector which has unit magnitude and same direction as that of  $\vec{A}$ .

Two vector  $\vec{A}$  and  $\vec{B}$  are added together to give another vector  $\vec{C}$ . We have

$$\vec{C} = \vec{A} + \vec{B} \dots\dots\dots(1.1)$$

Let us see the animations in the next pages for the addition of two vectors, which has two rules: **1: Parallelogram law** and **2: Head & tail rule**

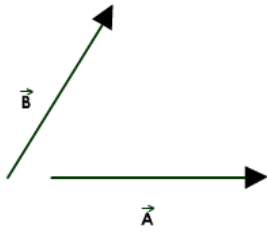

PLAY

STOP

HEAD TO TAIL RULE FOR VECTOR ADDITION

USE THE **PLAY** AND **STOP** BUTTONS TO VIEW HOW THE  
VECTORS A AND B ARE ADDED AND THE RESULTANT C IS  
PRODUCED

Fig 1.1(b): Vector Addition (Head & Tail Rule)

---

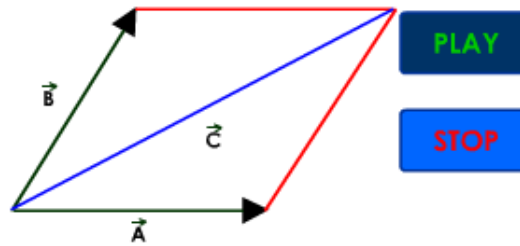

#### PARALLELOGRAM RULE FOR VECTOR ADDITION

USE THE **PLAY** AND **STOP** BUTTONS TO VIEW HOW THE VECTORS A AND B ARE ADDED AND THE RESULTANT C IS PRODUCED

Fig 1.1(a): Vector Addition (Parallelogram Rule)

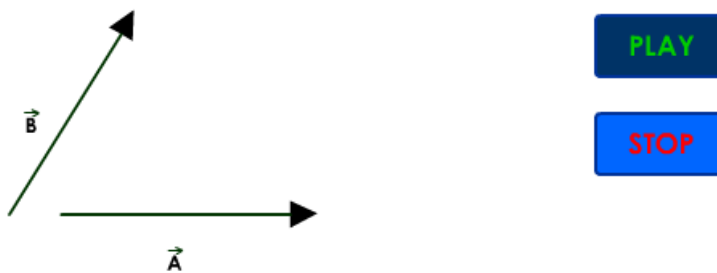

#### HEAD TO TAIL RULE FOR VECTOR ADDITION

USE THE **PLAY** AND **STOP** BUTTONS TO VIEW HOW THE VECTORS A AND B ARE ADDED AND THE RESULTANT C IS PRODUCED

Fig 1.1(b): Vector Addition (Head & Tail Rule)

### VECTOR ADDITION

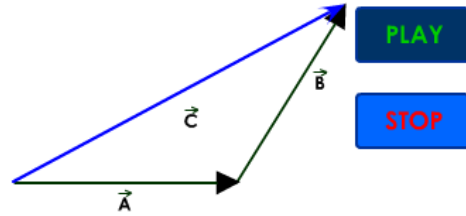

#### HEAD TO TAIL RULE FOR VECTOR ADDITION

USE THE **PLAY** AND **STOP** BUTTONS TO VIEW HOW THE VECTORS A AND B ARE ADDED AND THE RESULTANT C IS PRODUCED

Fig 1.1(b): Vector Addition (Head & Tail Rule)

Vector Subtraction is similarly carried out:  $\vec{D} = \vec{A} - \vec{B} = \vec{A} + (-\vec{B})$  .....(1.2)

### VECTOR SUBTRACTION

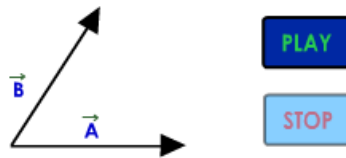

CLICK **PLAY** AND **STOP** TO SEE THE VECTOR SUBTRACTION OF A AND B

Fig 1.2: Vector subtraction

Vector Subtraction is similarly carried out:  $\vec{D} = \vec{A} - \vec{B} = \vec{A} + (-\vec{B})$  .....(1.2)

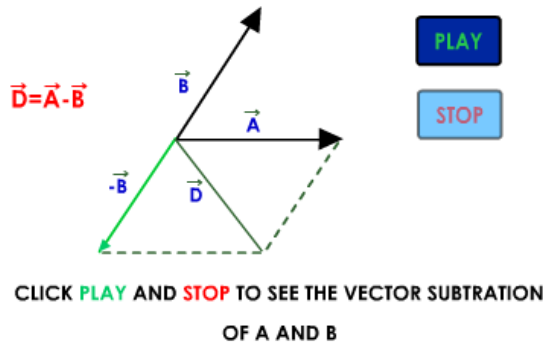

Fig 1.2: Vector subtraction

Scaling of a vector is defined as  $\vec{C} = \alpha \vec{B}$ , where  $\vec{C}$  is scaled version of vector  $\vec{B}$  and  $\alpha$  is a scalar.

Some important laws of vector algebra are:

$\vec{A} + \vec{B} = \vec{B} + \vec{A}$  Commutative Law.....(1.3)

$\vec{A} + (\vec{B} + \vec{C}) = (\vec{A} + \vec{B}) + \vec{C}$  Associative Law.....(1.4)

$\alpha(\vec{A} + \vec{B}) = \alpha\vec{A} + \alpha\vec{B}$  Distributive Law .....(1.5)

The position vector  $\vec{r}_P$  of a point  $P$  is the directed distance from the origin ( $O$ ) to  $P$ , i.e.,  $\vec{r}_P = \vec{OP}$ .

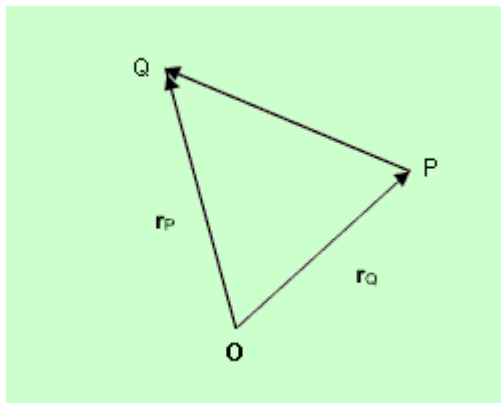

Fig 1.3: Distance Vector

If  $\vec{r}_Q = \vec{OP}$  and  $\vec{r}_P = \vec{OQ}$  are the position vectors of the points P and Q then the distance vector

$$\vec{PQ} = \vec{OQ} - \vec{OP} = \vec{r}_P - \vec{r}_Q$$

**Product of Vectors**

When two vectors  $\vec{A}$  and  $\vec{B}$  are multiplied, the result is either a scalar or a vector depending how the two vectors were multiplied. The two types of vector multiplication are:

Scalar product (or dot product)  $\vec{A} \cdot \vec{B}$  gives a scalar.

Vector product (or cross product)  $\vec{A} \times \vec{B}$  gives a vector.

The dot product between two vectors is defined as  $\vec{A} \cdot \vec{B} = |A||B|\cos\theta_{AB}$  .....(1.6)

Vector product  $\vec{A} \times \vec{B} = |A||B|\sin\theta_{AB} \cdot \vec{n}$

$\vec{n}$  is unit vector perpendicular to  $\vec{A}$  and  $\vec{B}$

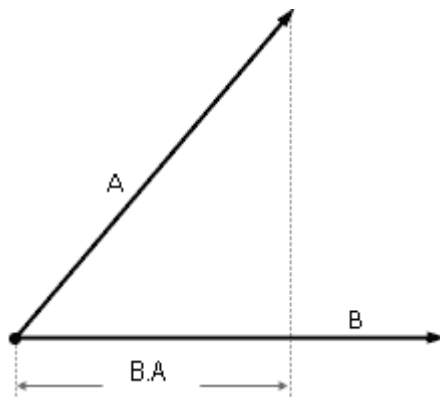

**Fig 1.4: Vector dot product**

The dot product is commutative i.e.,  $\vec{A} \cdot \vec{B} = \vec{B} \cdot \vec{A}$  and distributive i.e.,

$$\vec{A} \cdot (\vec{B} + \vec{C}) = \vec{A} \cdot \vec{B} + \vec{A} \cdot \vec{C}$$

. Associative law does not apply to scalar product.

The vector or cross product of two vectors  $\vec{A}$  and  $\vec{B}$  is denoted by  $\vec{A} \times \vec{B}$ .  $\vec{A} \times \vec{B}$  is a vector

perpendicular to the plane containing  $\vec{A}$  and  $\vec{B}$ , the magnitude is given by  $|A||B|\sin\theta_{AB}$  and direction is given by right hand rule as explained in Figure 1.5.



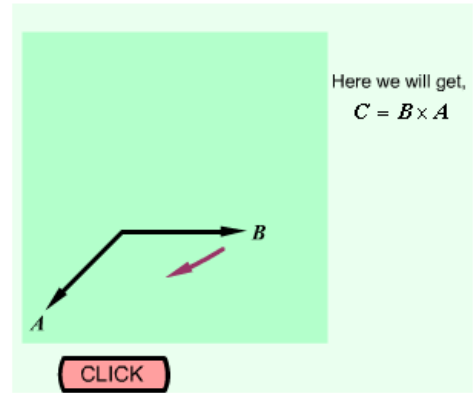
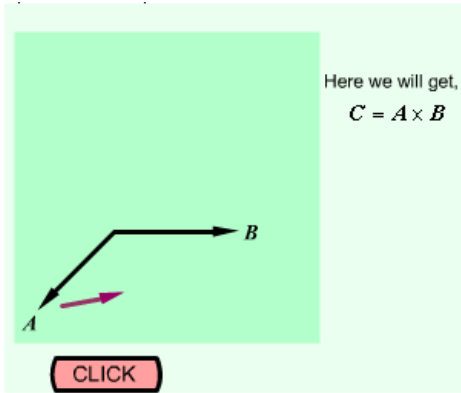

Fig 1.5 :Illustrating the left thumb rule for determining the vector cross product

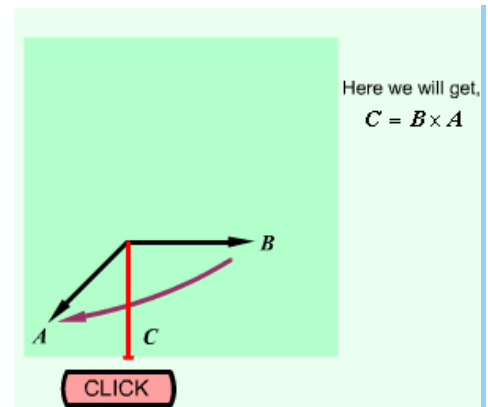
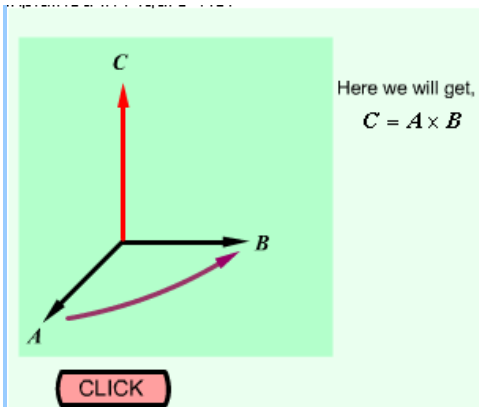

Fig 1.5 :Illustrating the left thumb rule for determining the vector cross product

[Next](#)

$$\vec{A} \times \vec{B} = \hat{a}_n AB \sin \theta_{AB} \dots\dots\dots(1.7)$$

where  $\hat{a}_n$  is the unit vector given by,  $\hat{a}_n = \frac{\vec{A} \times \vec{B}}{|\vec{A} \times \vec{B}|}$ .

The following relations hold for vector product.

$$\vec{A} \times \vec{B} = -\vec{B} \times \vec{A} \quad \text{i.e., cross product is non commutative .....(1.8)}$$

$$\vec{A} \times (\vec{B} + \vec{C}) = \vec{A} \times \vec{B} + \vec{A} \times \vec{C} \quad \text{i.e., cross product is distributive.....(1.9)}$$

$$\vec{A} \times (\vec{B} \times \vec{C}) \neq (\vec{A} \times \vec{B}) \times \vec{C} \quad \text{i.e., cross product is non associative.....(1.10)}$$

**Scalar and vector triple product :**

Scalar triple product  $\vec{A} \cdot (\vec{B} \times \vec{C}) = \vec{B} \cdot (\vec{C} \times \vec{A}) = \vec{C} \cdot (\vec{A} \times \vec{B}) \dots\dots\dots(1.11)$

Vector triple product  $\vec{A} \times (\vec{B} \times \vec{C}) = \vec{B} (\vec{A} \cdot \vec{C}) - \vec{C} (\vec{A} \cdot \vec{B}) \dots\dots\dots(1.12)$

**Co-ordinate Systems**

In order to describe the spatial variations of the quantities, we require using appropriate co-ordinate system. A point or vector can be represented in a **curvilinear** coordinate system that may be **orthogonal** or **non-orthogonal** .

An orthogonal system is one in which the co-ordinates are mutually perpendicular. Non-orthogonal co-ordinate systems are also possible, but their usage is very limited in practice .

Let  $u = \text{constant}$ ,  $v = \text{constant}$  and  $w = \text{constant}$  represent surfaces in a coordinate system,

the surfaces may be curved surfaces in general. Furthur, let  $\hat{a}_u$ ,  $\hat{a}_v$  and  $\hat{a}_w$  be the unit vectors in the three coordinate directions(base vectors). In a general right handed orthogonal curvilinear systems, the vectors satisfy the following relations :

$$\begin{aligned} \hat{a}_u \times \hat{a}_v &= \hat{a}_w \\ \hat{a}_v \times \hat{a}_w &= \hat{a}_u \\ \hat{a}_w \times \hat{a}_u &= \hat{a}_v \dots\dots\dots(1.13) \end{aligned}$$

These equations are not independent and specification of one will automatically imply the other two. Furthermore, the following relations hold

$$\begin{aligned} \hat{a}_u \cdot \hat{a}_v &= \hat{a}_v \cdot \hat{a}_w = \hat{a}_w \cdot \hat{a}_u = 0 \\ \hat{a}_u \cdot \hat{a}_u &= \hat{a}_v \cdot \hat{a}_v = \hat{a}_w \cdot \hat{a}_w = 1 \dots\dots\dots(1.14) \end{aligned}$$

A vector can be represented as sum of its orthogonal components,  $\vec{A} = A_u \hat{a}_u + A_v \hat{a}_v + A_w \hat{a}_w$  .....(1.15)

In general  $u, v$  and  $w$  may not represent length. We multiply  $u, v$  and  $w$  by conversion factors  $h_1, h_2$  and  $h_3$  respectively to convert differential changes  $du, dv$  and  $dw$  to corresponding changes in length  $dl_1, dl_2$ , and  $dl_3$ . Therefore

$$d\vec{l} = \hat{a}_u dl_1 + \hat{a}_v dl_2 + \hat{a}_w dl_3$$

$$= h_1 du \hat{a}_u + h_2 dv \hat{a}_v + h_3 dw \hat{a}_w$$
 .....(1.16)

In the same manner, differential volume  $dv$  can be written as  $dv = h_1 h_2 h_3 du dv dw$  and differential area  $ds_1$  normal to  $\hat{a}_u$  is given by,  $ds_1 = h_2 h_3 dv dw$ . In the same manner, differential areas normal to unit vectors  $\hat{a}_v$  and  $\hat{a}_w$  can be defined.

**In the following sections we discuss three most commonly used orthogonal co-ordinate systems, viz:**

1. Cartesian (or rectangular) co-ordinate system
2. Cylindrical co-ordinate system
3. Spherical polar co-ordinate system

**Cartesian Co-ordinate System :**

In Cartesian co-ordinate system, we have,  $(u, v, w) = (x, y, z)$ . A point  $P(x_0, y_0, z_0)$  in Cartesian co-ordinate system is represented as intersection of three planes  $x = x_0, y = y_0$  and  $z = z_0$ . The unit vectors satisfies the following relation:

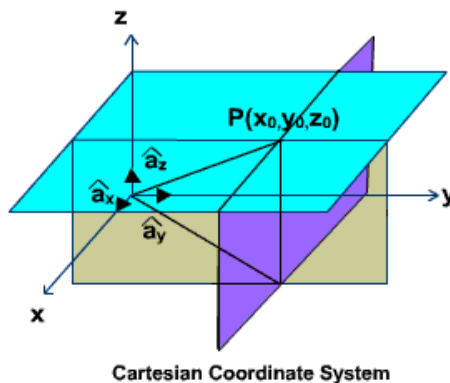

$$\begin{aligned} \hat{a}_x \times \hat{a}_y &= \hat{a}_z \\ \hat{a}_y \times \hat{a}_z &= \hat{a}_x \\ \hat{a}_z \times \hat{a}_x &= \hat{a}_y \\ \hat{a}_x \cdot \hat{a}_y &= \hat{a}_y \cdot \hat{a}_z = \hat{a}_z \cdot \hat{a}_x = 0 \\ \hat{a}_x \cdot \hat{a}_x &= \hat{a}_y \cdot \hat{a}_y = \hat{a}_z \cdot \hat{a}_z = 1 \end{aligned}$$

$$\vec{OP} = \hat{a}_x x_0 + \hat{a}_y y_0 + \hat{a}_z z_0$$

In cartesian co-ordinate system, a vector  $\vec{A}$  can be written as  $\vec{A} = \hat{a}_x A_x + \hat{a}_y A_y + \hat{a}_z A_z$ .

The dot and cross product of two vectors  $\vec{A}$  and  $\vec{B}$  can be written as follows:

$$\vec{A} \cdot \vec{B} = A_x B_x + A_y B_y + A_z B_z \dots\dots\dots(1.19)$$

$$\begin{aligned} \vec{A} \times \vec{B} &= \hat{a}_x (A_y B_z - A_z B_y) + \hat{a}_y (A_z B_x - A_x B_z) + \hat{a}_z (A_x B_y - A_y B_x) \\ &= \begin{vmatrix} \hat{a}_x & \hat{a}_y & \hat{a}_z \\ A_x & A_y & A_z \\ B_x & B_y & B_z \end{vmatrix} \end{aligned}$$

.....(1.20)

Since  $x, y$  and  $z$  all represent lengths,  $h_1 = h_2 = h_3 = 1$ . The differential length, area and volume are defined respectively as

$$d\vec{l} = dx \hat{a}_x + dy \hat{a}_y + dz \hat{a}_z \dots\dots\dots(1.21)$$

$$d\vec{s}_x = dydz \hat{a}_x$$

$$d\vec{s}_y = dx dz \hat{a}_y$$

$$d\vec{s}_z = dx dy \hat{a}_z$$

$$dV = dx dy dz \dots\dots\dots(1.22)$$

**Cylindrical Co-ordinate System :**

For cylindrical coordinate systems we have  $(u, v, w) = (r, \phi, z)$  a point  $P(r_0, \phi_0, z_0)$  is determined as the point of intersection of a cylindrical surface  $r = r_0$ , half plane

containing the z-axis and making an angle  $\phi = \phi_0$ ; with the xz plane and a plane parallel to xy plane located at  $z=z_0$  as shown in figure 7 on next page.

In cylindrical coordinate system, the unit vectors satisfy the following relations

A vector  $\vec{A}$  can be written as ,  $\vec{A} = A_\rho \hat{a}_\rho + A_\phi \hat{a}_\phi + A_z \hat{a}_z$  .....(1.24)

The differential length is defined as,

$$d\vec{l} = \hat{a}_\rho d\rho + \rho d\phi \hat{a}_\phi + dz \hat{a}_z \quad h_1 = 1, h_2 = \rho, h_3 = 1 \quad \text{.....(1.25)}$$

$$\begin{aligned} \hat{a}_\rho \times \hat{a}_\phi &= \hat{a}_z \\ \hat{a}_\phi \times \hat{a}_z &= \hat{a}_\rho \\ \hat{a}_z \times \hat{a}_\rho &= \hat{a}_\phi \quad \text{.....(1.23)} \end{aligned}$$

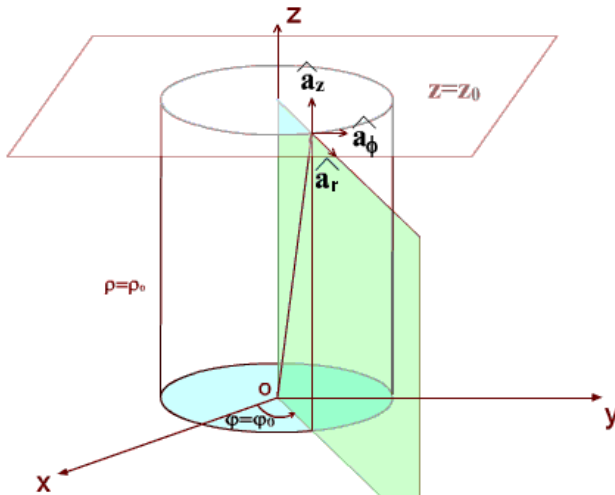

Fig 1.7 : Cylindrical Coordinate System

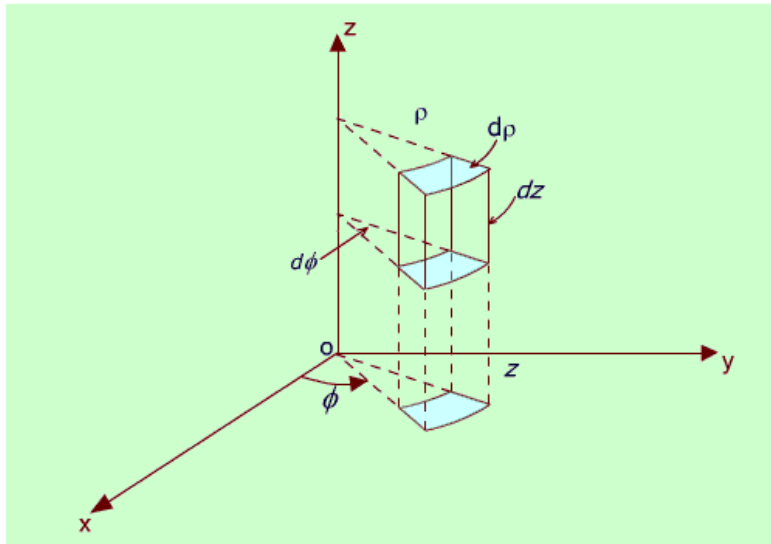

Fig 1.8 : Differential Volume Element in Cylindrical Coordinates

Differential areas are:

$$\begin{aligned} \vec{ds}_\rho &= \rho d\phi dz \hat{a}_\rho \\ \vec{ds}_\phi &= d\rho dz \hat{a}_\phi \quad \dots\dots\dots(1.26) \\ \vec{ds}_z &= \rho d\rho d\phi \hat{a}_z \end{aligned}$$

Differential volume,

$$dV = \rho d\rho d\phi dz \quad \dots\dots\dots(1.27)$$

**Transformation between Cartesian and Cylindrical coordinates:**

Let us consider  $\vec{A} = \hat{a}_\rho A_\rho + \hat{a}_\phi A_\phi + \hat{a}_z A_z$  is to be expressed in Cartesian co-ordinate as

$$\vec{A} = \hat{a}_x A_x + \hat{a}_y A_y + \hat{a}_z A_z. \quad \text{In doing so we note that} \quad A_x = \vec{A} \cdot \hat{a}_x = \left( \hat{a}_\rho A_\rho + \hat{a}_\phi A_\phi + \hat{a}_z A_z \right) \cdot \hat{a}_x$$

and it applies for other components as well.

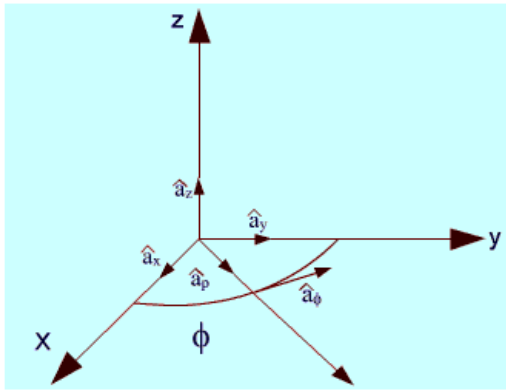

Fig 1.9 : Unit Vectors in Cartesian and Cylindrical Coordinates

$$\begin{aligned} \hat{a}_\rho \cdot \hat{a}_x &= \cos \phi \\ \hat{a}_\rho \cdot \hat{a}_y &= \sin \phi \\ \hat{a}_\phi \cdot \hat{a}_x &= \cos(\phi + \frac{\pi}{2}) = -\sin \phi \end{aligned} \dots\dots\dots(1.28)$$

$$\begin{aligned} \hat{a}_\phi \cdot \hat{a}_y &= \cos \phi \\ \text{Therefore we can write,} \\ A_x &= \vec{A} \cdot \hat{a}_x = A_\rho \cos \phi - A_\phi \sin \phi \\ A_y &= \vec{A} \cdot \hat{a}_y = A_\rho \sin \phi + A_\phi \cos \phi \dots\dots\dots(1.29) \\ A_z &= \vec{A} \cdot \hat{a}_z = A_z \end{aligned}$$

These relations can be put conveniently in the matrix form as:

$$\begin{bmatrix} A_x \\ A_y \\ A_z \end{bmatrix} = \begin{bmatrix} \cos \phi & -\sin \phi & 0 \\ \sin \phi & \cos \phi & 0 \\ 0 & 0 & 1 \end{bmatrix} \begin{bmatrix} A_\rho \\ A_\phi \\ A_z \end{bmatrix} \dots\dots\dots(1.30)$$

$A_\rho, A_\phi$  and  $A_z$  themselves may be functions of  $\rho, \phi$  and  $z$  as:

$$\begin{aligned} x &= \rho \cos \phi \\ y &= \rho \sin \phi \\ z &= z \end{aligned} \dots\dots\dots(1.31)$$

$$\begin{aligned} \rho &= \sqrt{x^2 + y^2} \\ \phi &= \tan^{-1} \frac{y}{x} \end{aligned}$$

The inverse relationships are:  $z = z \dots\dots\dots(1.32)$

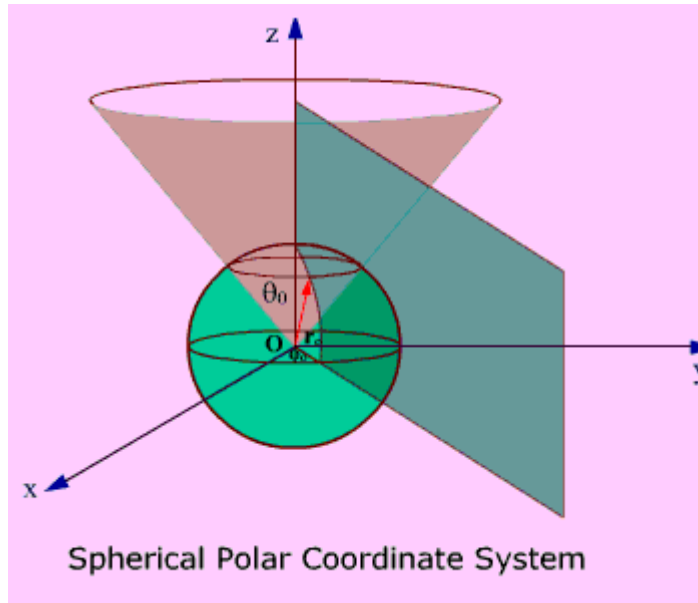

**Fig 1.10: Spherical Polar Coordinate System**

Thus we see that a vector in one coordinate system is transformed to another coordinate system through two-step process: Finding the component vectors and then variable transformation.

Spherical Polar Coordinates:

For spherical polar coordinate system, we have,  $(u, v, w) = (r, \theta, \phi)$ . A point  $P(r_0, \theta_0, \phi_0)$  is represented as the intersection of

- (i) Spherical surface  $r=r_0$
- (ii) Conical surface  $\theta = \theta_0$ , and
- (iii) half plane containing z-axis making angle  $\phi = \phi_0$  with the xz plane as shown in the figure 1.10.

$$\begin{aligned} \hat{a}_r \times \hat{a}_\theta &= \hat{a}_\phi \\ \hat{a}_\theta \times \hat{a}_\phi &= \hat{a}_r \\ \hat{a}_\phi \times \hat{a}_r &= \hat{a}_\theta \end{aligned}$$

The unit vectors satisfy the following relationships:  
 .....(1.33)

The orientation of the unit vectors are shown in the figure 1.11.



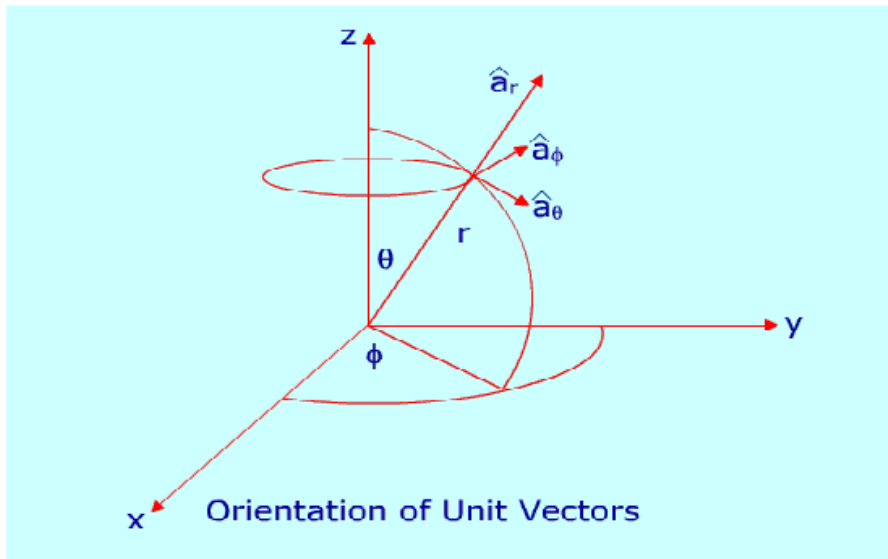

Fig 1.11: Orientation of Unit Vectors

A vector in spherical polar co-ordinates is written as :  $\vec{A} = A_r \hat{a}_r + A_\theta \hat{a}_\theta + A_\phi \hat{a}_\phi$  and

$$d\vec{l} = \hat{a}_r dr + \hat{a}_\theta r d\theta + \hat{a}_\phi r \sin \theta d\phi$$

For spherical polar coordinate system we have  $h_1=1$ ,  $h_2=r$  and  $h_3=r \sin \theta$ .

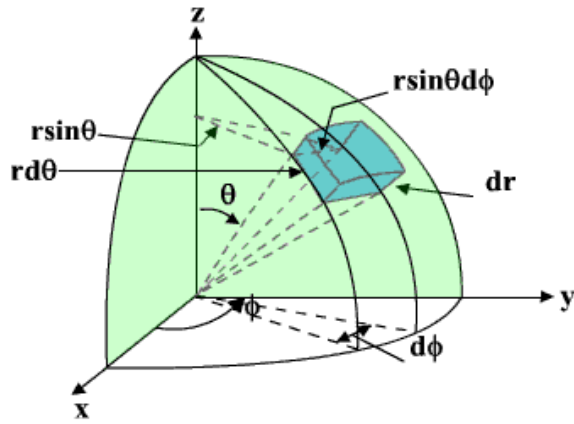

Fig 1.12(a) : Differential volume in s-p coordinates

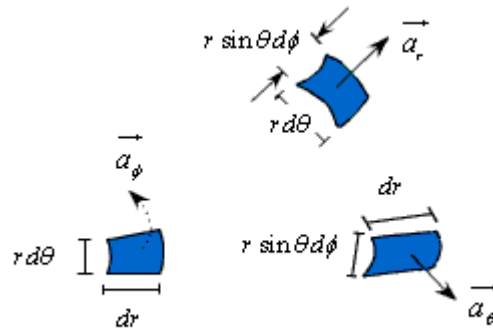

Fig 1.12(b) : Exploded view

With reference to the Figure 1.12, the elemental areas are:

$$\begin{aligned}
 ds_r &= r^2 \sin \theta d\theta d\phi \hat{a}_r \\
 ds_\theta &= r \sin \theta dr d\phi \hat{a}_\theta \\
 ds_\phi &= r dr d\theta \hat{a}_\phi \quad \dots\dots\dots(1.34)
 \end{aligned}$$

and elementary volume is given by

$$dV = r^2 \sin \theta dr d\theta d\phi \quad \dots\dots\dots(1.35)$$

**Coordinate transformation between rectangular and spherical polar:**

With reference to the figure 1.13 ,we can write the following equations:

$$\begin{aligned}
 \hat{a}_r \cdot \hat{a}_x &= \sin \theta \cos \phi \\
 \hat{a}_r \cdot \hat{a}_y &= \sin \theta \sin \phi \\
 \hat{a}_r \cdot \hat{a}_z &= \cos \theta \\
 \hat{a}_\theta \cdot \hat{a}_x &= \cos \theta \cos \phi \\
 \hat{a}_\theta \cdot \hat{a}_y &= \cos \theta \sin \phi \\
 \hat{a}_\theta \cdot \hat{a}_z &= \cos\left(\theta + \frac{\pi}{2}\right) = -\sin \theta \\
 \hat{a}_\phi \cdot \hat{a}_x &= \cos\left(\phi + \frac{\pi}{2}\right) = -\sin \phi \\
 \hat{a}_\phi \cdot \hat{a}_y &= \cos \phi \\
 \hat{a}_\phi \cdot \hat{a}_z &= 0
 \end{aligned}
 \dots\dots\dots(1.36)$$

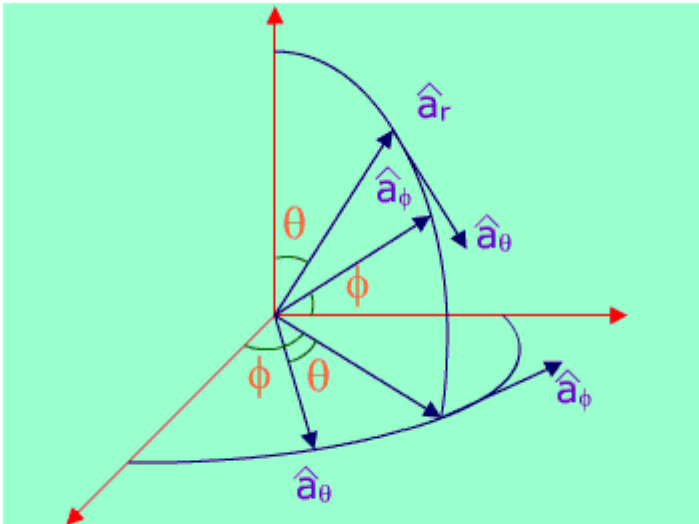

**Fig 1.13: Coordinate transformation**

Given a vector  $\vec{A} = A_r \hat{a}_r + A_\theta \hat{a}_\theta + A_\phi \hat{a}_\phi$  in the spherical polar coordinate system, its component in the cartesian coordinate system can be found out as follows:

$$A_x = \vec{A} \cdot \hat{a}_x = A_r \sin \theta \cos \phi + A_\theta \cos \theta \cos \phi - A_\phi \sin \phi \dots\dots\dots(1.37)$$

Similarly,

$$A_y = \vec{A} \cdot \hat{\alpha}_y = A_r \sin \theta \sin \phi + A_\theta \cos \theta \sin \phi + A_\phi \cos \phi \dots\dots\dots(1.38a)$$

$$A_x = \vec{A} \cdot \hat{\alpha}_x = A_r \cos \theta - A_\theta \sin \theta \dots\dots\dots(1.38b)$$

The above equation can be put in a compact form:

$$\begin{bmatrix} A_x \\ A_y \\ A_z \end{bmatrix} = \begin{bmatrix} \sin \theta \cos \phi & \cos \theta \cos \phi & -\sin \phi \\ \sin \theta \sin \phi & \cos \theta \sin \phi & \cos \phi \\ \cos \theta & -\sin \theta & 0 \end{bmatrix} \begin{bmatrix} A_r \\ A_\theta \\ A_\phi \end{bmatrix} \dots\dots\dots(1.39)$$

The components  $A_r, A_\theta$  and  $A_\phi$  themselves will be functions of  $r, \theta$  and  $\phi$ .  $r, \theta$  and  $\phi$  are related to  $x, y$  and  $z$  as:

$$\begin{aligned} x &= r \sin \theta \cos \phi \\ y &= r \sin \theta \sin \phi \\ z &= r \cos \theta \dots\dots\dots(1.40) \end{aligned}$$

and conversely,

$$r = \sqrt{x^2 + y^2 + z^2} \dots\dots\dots(1.41a)$$

$$\theta = \cos^{-1} \frac{z}{\sqrt{x^2 + y^2 + z^2}} \dots\dots\dots(1.41b)$$

$$\phi = \tan^{-1} \frac{y}{x} \dots\dots\dots(1.41c)$$

Using the variable transformation listed above, the vector components, which are functions of variables of one coordinate system, can be transformed to functions of variables of other coordinate system and a total transformation can be done.

**Line, surface and volume integrals**

In electromagnetic theory, we come across integrals, which contain vector functions. Some representative integrals are listed below:

$$\int_V \vec{F} dv \quad \int_S \phi d\vec{l} \quad \int_C \vec{F} d\vec{l} \quad \int_S \vec{F} \cdot d\vec{s}$$

In the above integrals,  $\vec{F}$  and  $\phi$  respectively represent vector and scalar function of space coordinates.  $C, S$  and  $V$  represent path, surface and volume of integration. All these integrals are evaluated using extension of the usual one-dimensional integral as the limit of a sum, i.e., if a function  $f(x)$  is defined over arrange  $a$  to  $b$  of values of  $x$ , then the integral is given by

$$\int_a^b f(x) dx = \lim_{n \rightarrow \infty} \sum_{i=1}^n f_i \delta x_i \dots\dots\dots(1.42)$$

where the interval  $(a, b)$  is subdivided into  $n$  continuous interval of lengths  $\delta x_1, \dots, \delta x_n$ .

**Line Integral:** Line integral  $\int_C \vec{E} \cdot d\vec{l}$  is the dot product of a vector with a specified  $C$ ; in other words it is the integral of the tangential component  $\vec{E}$  along the curve  $C$ .

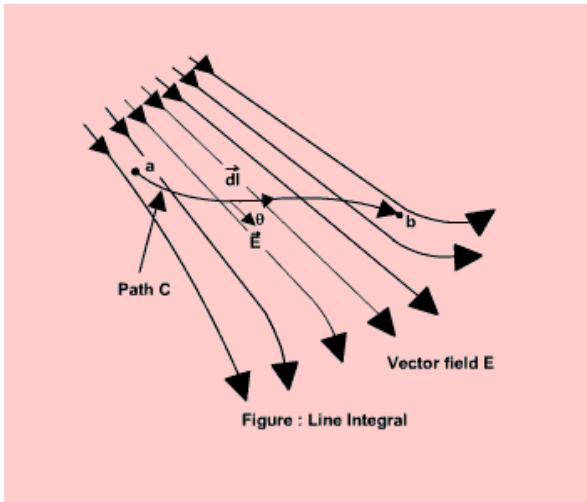

**Fig 1.14: Line Integral**

As shown in the figure 1.14, given a vector  $\vec{E}$  around  $C$ , we define the integral

$$\int_C \vec{E} \cdot d\vec{l} = \int_a^b E \cos \theta dl$$

as the line integral of  $E$  along the curve  $C$ .

If the path of integration is a closed path as shown in the figure the line integral becomes

a closed line integral and is called the circulation of  $\vec{E}$  around  $C$  and denoted as  $\oint_C \vec{E} \cdot d\vec{l}$  as shown in the figure 1.15.

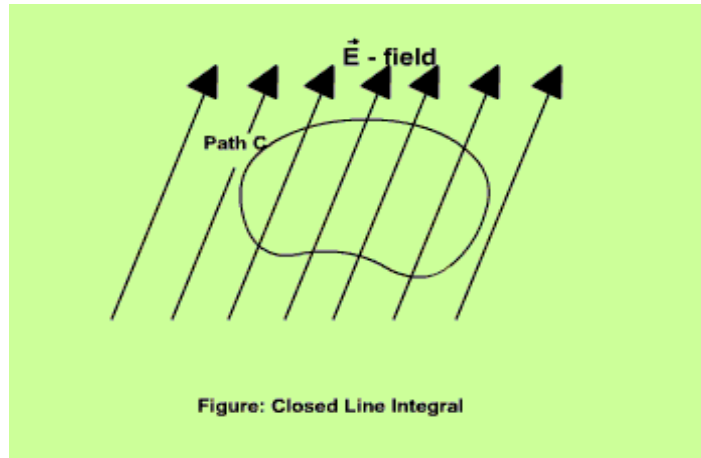

**Fig 1.15: Closed Line Integral**

### Surface Integral :

Given a vector field  $\vec{A}$ , continuous in a region containing the smooth surface  $S$ , we define the surface integral or the flux of  $\vec{A}$  through  $S$  as

$$\psi = \int_S A \cos \theta dS = \int_S \vec{A} \cdot \hat{a}_n dS = \int_S \vec{A} d\vec{S}$$

as surface integral over surface  $S$ .

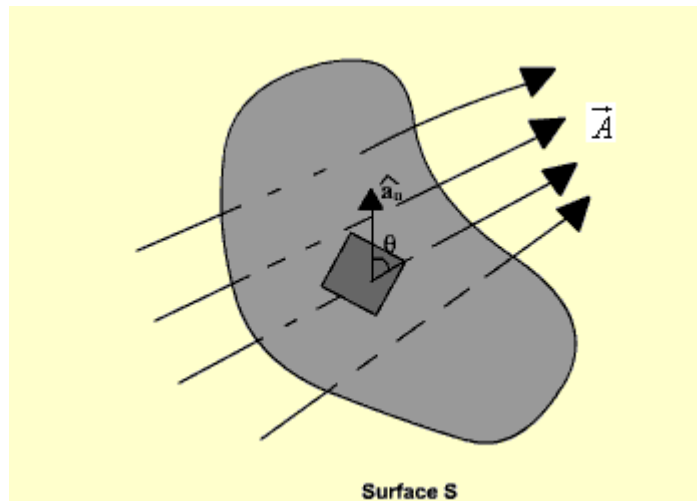

**Fig 1.16 : Surface Integral**

If the surface integral is carried out over a closed surface, then we write

$$\psi = \oint_S \vec{A} d\vec{S}$$

### Volume Integrals:

We define  $\int_V f dV$  or  $\iiint_V f dV$  as the volume integral of the scalar function  $f$  (function of spatial coordinates) over the volume  $V$ . Evaluation of integral of the form  $\int_V \vec{F} dV$  can be carried out as a sum of three scalar volume integrals, where each scalar volume integral is a component of the vector  $\vec{F}$ .

### The Del Operator :

The vector differential operator  $\nabla$  was introduced by Sir W. R. Hamilton and later on developed by P. G. Tait.

Mathematically the vector differential operator can be written in the general form as:

$$\nabla = \frac{1}{h_1} \frac{\partial}{\partial u} \hat{a}_u + \frac{1}{h_2} \frac{\partial}{\partial v} \hat{a}_v + \frac{1}{h_3} \frac{\partial}{\partial w} \hat{a}_w \quad \dots\dots\dots(1.43)$$

### Gradient of a Scalar function:

In Cartesian coordinates:

$$\nabla = \frac{\partial}{\partial x} \hat{a}_x + \frac{\partial}{\partial y} \hat{a}_y + \frac{\partial}{\partial z} \hat{a}_z \quad \dots\dots\dots(1.44)$$

In cylindrical coordinates:

$$\nabla = \frac{\partial}{\partial \rho} \hat{a}_\rho + \frac{1}{\rho} \frac{\partial}{\partial \phi} \hat{a}_\phi + \frac{\partial}{\partial z} \hat{a}_z \quad \dots\dots\dots(1.45)$$

and in spherical polar coordinates:

$$\nabla = \frac{\partial}{\partial r} \hat{a}_r + \frac{1}{r} \frac{\partial}{\partial \theta} \hat{a}_\theta + \frac{1}{r \sin \theta} \frac{\partial}{\partial \phi} \hat{a}_\phi \quad \dots\dots\dots(1.46)$$

Let us consider a scalar field  $V(u,v,w)$ , a function of space coordinates.

Gradient of the scalar field  $V$  is a vector that represents both the magnitude and direction of the maximum space rate of increase of this scalar field  $V$ .

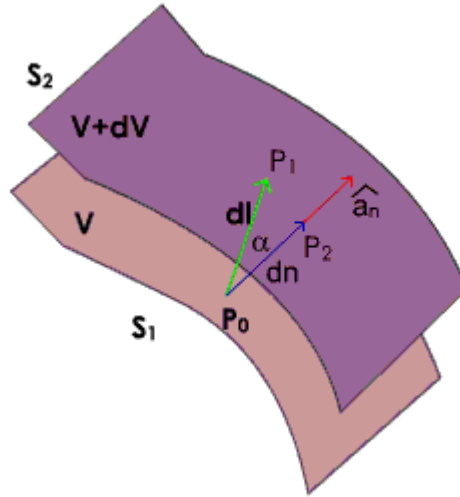

**Fig 1.17 : Gradient of a scalar function**

As shown in figure 1.17, let us consider two surfaces  $S_1$  and  $S_2$  where the function  $V$  has constant magnitude and the magnitude differs by a small amount  $dV$ . Now as one moves from  $S_1$  to  $S_2$ , the magnitude of spatial rate of change of  $V$  i.e.  $dV/dl$  depends on the direction of elementary path length  $dl$ , the maximum occurs when one traverses from  $S_1$  to  $S_2$  along a path normal to the surfaces as in this case the distance is minimum.

By our definition of gradient we can write:

$$\text{grad}V = \frac{dV}{dn} \hat{a}_n = \nabla V$$

.....(1.47)

since  $d\vec{n}$  which represents the distance along the normal is the shortest distance between the two surfaces.

For a general curvilinear coordinate system

$$d\vec{l} = \hat{a}_u du + \hat{a}_v dv + \hat{a}_w dw = \left( h_1 du \hat{a}_u + h_2 dv \hat{a}_v + h_3 dw \hat{a}_w \right)$$

.....(1.48)

Further we can write

$$\frac{dV}{dl} = \frac{dV}{dn} \frac{dn}{dl} = \frac{dV}{dn} \cos \alpha = \nabla V \cdot \hat{a}_l$$

.....(1.49)

Hence,



$$dV = \nabla V \cdot dl = \nabla V \cdot (h_1 du \hat{a}_u + h_2 dv \hat{a}_v + h_3 dw \hat{a}_w) \quad \dots\dots\dots(1.50)$$

Also we can write,

$$\begin{aligned} dV &= \frac{\partial V}{\partial l_u} dl_u + \frac{\partial V}{\partial l_v} dl_v + \frac{\partial V}{\partial l_w} dl_w \\ &= \left( \frac{\partial V}{\partial l_u} \hat{a}_u + \frac{\partial V}{\partial l_v} \hat{a}_v + \frac{\partial V}{\partial l_w} \hat{a}_w \right) \cdot (dl_u \hat{a}_u + dl_v \hat{a}_v + dl_w \hat{a}_w) \\ &= \left( \frac{\partial V}{h_1 \partial u} \hat{a}_u + \frac{\partial V}{h_2 \partial v} \hat{a}_v + \frac{\partial V}{h_3 \partial w} \hat{a}_w \right) \cdot (h_1 du \hat{a}_u + h_2 dv \hat{a}_v + h_3 dw \hat{a}_w) \end{aligned} \quad \dots\dots\dots(1.51)$$

By comparison we can write,

$$\nabla V = \frac{1}{h_1} \frac{\partial V}{\partial u} \hat{a}_u + \frac{1}{h_2} \frac{\partial V}{\partial v} \hat{a}_v + \frac{1}{h_3} \frac{\partial V}{\partial w} \hat{a}_w \quad \dots\dots\dots(1.52)$$

Hence for the Cartesian, cylindrical and spherical polar coordinate system, the expressions for gradient can be written as:

In Cartesian coordinates:

$$\nabla V = \frac{\partial V}{\partial x} \hat{a}_x + \frac{\partial V}{\partial y} \hat{a}_y + \frac{\partial V}{\partial z} \hat{a}_z \quad \dots\dots\dots(1.53)$$

In cylindrical coordinates:

$$\nabla V = \frac{\partial V}{\partial \rho} \hat{a}_\rho + \frac{1}{\rho} \frac{\partial V}{\partial \phi} \hat{a}_\phi + \frac{\partial V}{\partial z} \hat{a}_z \quad \dots\dots\dots(1.54)$$

and in spherical polar coordinates:

$$\nabla V = \frac{\partial V}{\partial r} \hat{a}_r + \frac{1}{r} \frac{\partial V}{\partial \theta} \hat{a}_\theta + \frac{1}{r \sin \theta} \frac{\partial V}{\partial \phi} \hat{a}_\phi \quad \dots\dots\dots(1.55)$$

The following relationships hold for gradient operator.

$$\begin{aligned} \nabla(U+V) &= \nabla U + \nabla V \\ \nabla(UV) &= V\nabla U + U\nabla V \\ \nabla\left(\frac{U}{V}\right) &= \frac{V\nabla U - U\nabla V}{V^2} \\ \nabla V^n &= nV^{n-1}\nabla V \end{aligned} \dots\dots\dots(1.56)$$

where  $U$  and  $V$  are scalar functions and  $n$  is an integer.

It may further be noted that since magnitude of  $\frac{dV}{dl} (= \Delta V \cdot \hat{a}_1)$  depends on the direction of  $dl$ , it is called the **directional derivative**. If  $A = \Delta V$ ,  $V$  is called the scalar potential function of the vector function  $\vec{A}$ .

**Divergence of a Vector Field:**

In study of vector fields, directed line segments, also called flux lines or streamlines, represent field variations graphically. The intensity of the field is proportional to the density of lines. For example, the number of flux lines passing through a unit surface  $S$  normal to the vector measures the vector field strength.

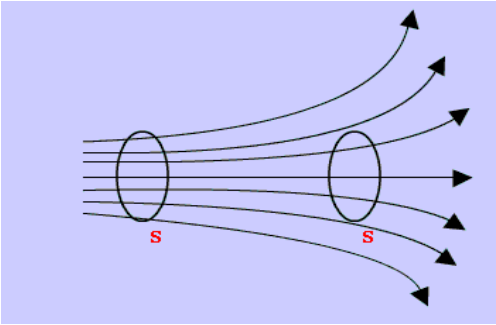

**Fig 1.18: Flux Lines**

We have already defined flux of a vector field as

$$\psi = \int_S A \cos \theta ds = \int_S \vec{A} \cdot \hat{a}_n ds = \int_S \vec{A} \cdot d\vec{s} \dots\dots\dots(1.57)$$

For a volume enclosed by a surface,

$$\psi = \oint_S \vec{A} \cdot d\vec{s} \dots\dots\dots(1.58)$$

We define the divergence of a vector field  $\vec{A}$  at a point  $P$  as the net outward flux from a volume enclosing  $P$ , as the volume shrinks to zero.

$$\text{div } \vec{A} = \nabla \cdot \vec{A} = \lim_{\Delta V \rightarrow 0} \frac{\oint_S \vec{A} \cdot d\vec{s}}{\Delta V} \dots\dots\dots(1.59)$$

Here  $\Delta V$  is the volume that encloses  $P$  and  $S$  is the corresponding closed surface.

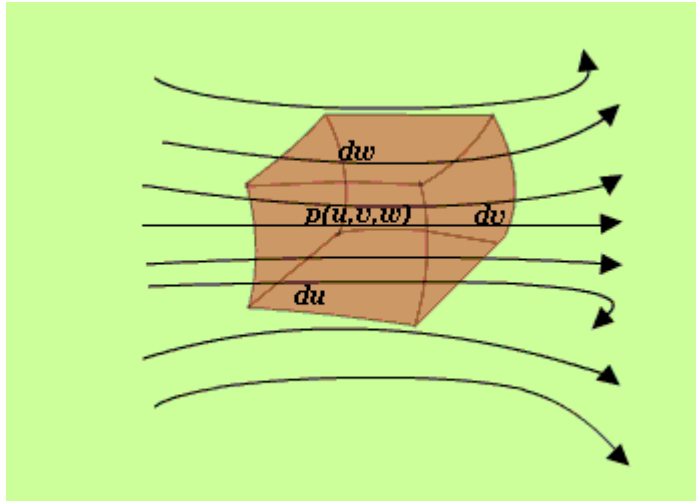

**Fig 1.19: Evaluation of divergence in curvilinear coordinate**

Let us consider a differential volume centered on point  $P(u, v, w)$  in a vector field  $\vec{A}$ . The flux through an elementary area normal to  $u$  is given by ,

$$\phi_u = \vec{A} \cdot \hat{a}_u h_2 h_3 du dv dw \dots\dots\dots(1.60)$$

Net outward flux along  $u$  can be calculated considering the two elementary surfaces perpendicular to  $u$

$$\left[ h_2 h_3 A_u \Big|_{\left(u+\frac{du}{2}, v, w\right)} - h_2 h_3 A_u \Big|_{\left(u-\frac{du}{2}, v, w\right)} \right] dv dw \cong \frac{\partial (h_2 h_3 A_u)}{\partial u} du dv dw \dots\dots\dots(1.61)$$

Considering the contribution from all six surfaces that enclose the volume, we can write

$$\text{div } \vec{A} = \nabla \cdot \vec{A} = \lim_{\Delta v \rightarrow 0} \frac{\oint_S \vec{A} \cdot d\vec{s}}{\Delta v} = \frac{du dv dw \frac{\partial(h_2 h_3 A_u)}{\partial u} + du dv dw \frac{\partial(h_1 h_3 A_v)}{\partial v} + du dv dw \frac{\partial(h_1 h_2 A_w)}{\partial w}}{h_1 h_2 h_3 du dv dw}$$

$$\therefore \nabla \cdot \vec{A} = \frac{1}{h_1 h_2 h_3} \left[ \frac{\partial(h_2 h_3 A_u)}{\partial u} + \frac{\partial(h_1 h_3 A_v)}{\partial v} + \frac{\partial(h_1 h_2 A_w)}{\partial w} \right] \dots\dots\dots(1.62)$$

Hence for the Cartesian, cylindrical and spherical polar coordinate system, the expressions for divergence are written as:

**In Cartesian coordinates:**

$$\nabla \cdot \vec{A} = \frac{\partial A_x}{\partial x} + \frac{\partial A_y}{\partial y} + \frac{\partial A_z}{\partial z} \dots\dots\dots(1.63)$$

In cylindrical coordinates:

$$\nabla \cdot \vec{A} = \frac{1}{\rho} \frac{\partial(\rho A_\rho)}{\partial \rho} + \frac{1}{\rho} \frac{\partial A_\phi}{\partial \phi} + \frac{\partial A_z}{\partial z} \dots\dots\dots(1.64)$$

and in spherical polar coordinates:

$$\nabla \cdot \vec{A} = \frac{1}{r^2} \frac{\partial(r^2 A_r)}{\partial r} + \frac{1}{r \sin \theta} \frac{\partial(\sin \theta A_\theta)}{\partial \theta} + \frac{1}{r \sin \theta} \frac{\partial A_\phi}{\partial \phi} \dots\dots\dots(1.65)$$

In connection with the divergence of a vector field, the following can be noted

- Divergence of a vector field gives a scalar.

$$\nabla \cdot (\vec{A} + \vec{B}) = \nabla \cdot \vec{A} + \nabla \cdot \vec{B}$$

- $\nabla \cdot (V \vec{A}) = V \nabla \cdot \vec{A} + \vec{A} \cdot \nabla V$  .....(1.66)

**Divergence theorem :**

Divergence theorem states that the volume integral of the divergence of vector field is equal to the net outward flux of the vector through the closed surface that bounds the

volume. Mathematically,  $\int_V \nabla \cdot \vec{A} dv = \oint_S \vec{A} \cdot d\vec{s}$

**Proof:**

Let us consider a volume  $V$  enclosed by a surface  $S$ . Let us subdivide the volume in large number of cells. Let the  $k^{th}$  cell has a volume  $\Delta V_k$  and the corresponding surface is denoted by  $S_k$ . Interior to the volume, cells have common surfaces. Outward flux through these common surfaces from one cell becomes the inward flux for the neighboring cells. Therefore when the total flux from these cells are considered, we actually get the net outward flux through the surface surrounding the volume. Hence we can write:

$$\oint_S \vec{A} \cdot d\vec{s} = \sum_k \oint_{S_k} \vec{A} \cdot d\vec{s} = \sum_k \frac{\oint_{S_k} \vec{A} \cdot d\vec{s}}{\Delta V_k} \Delta V_k \dots\dots\dots(1.67)$$

In the limit, that is when  $K \rightarrow \infty$  and  $\Delta V_k \rightarrow 0$  the right hand of the expression can be written as  $\int_V \nabla \cdot \vec{A} dV$ .

Hence we get  $\oint_S \vec{A} \cdot d\vec{S} = \int_V \nabla \cdot \vec{A} dV$ , which is the divergence theorem.

**Curl of a vector field:**

We have defined the circulation of a vector field  $A$  around a closed path as  $\oint \vec{A} \cdot d\vec{l}$ .

**Curl** of a vector field is a measure of the vector field's tendency to rotate about a point.  $\text{Curl } \vec{A}$ , also written as  $\nabla \times \vec{A}$  is defined as a vector whose magnitude is maximum of the net circulation per unit area when the area tends to zero and its direction is the normal direction to the area when the area is oriented in such a way so as to make the circulation maximum.

Therefore, we can write:

$$\text{Curl } \vec{A} = \nabla \times \vec{A} = \lim_{\Delta S \rightarrow 0} \frac{\hat{a}_n}{\Delta S} \left[ \oint \vec{A} \cdot d\vec{l} \right]_{\text{max}} \dots\dots\dots(1.68)$$

To derive the expression for curl in generalized curvilinear coordinate system, we first compute  $\nabla \times \vec{A} \cdot \hat{a}_u$  and to do so let us consider the figure 1.20 :

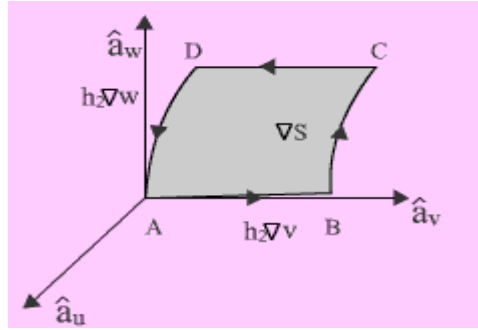

**Fig 1.20: Curl of a Vector**

$C_1$  represents the boundary of  $\Delta S$ , then we can write

$$\oint_{C_1} \vec{A} \cdot d\vec{l} = \int_{AB} \vec{A} \cdot d\vec{l} + \int_{BC} \vec{A} \cdot d\vec{l} + \int_{CD} \vec{A} \cdot d\vec{l} + \int_{DA} \vec{A} \cdot d\vec{l} \tag{1.69}$$

The integrals on the RHS can be evaluated as follows:

$$\int_{AB} \vec{A} \cdot d\vec{l} = (A_u \hat{a}_u + A_v \hat{a}_v + A_w \hat{a}_w) \cdot h_2 \Delta v \hat{a}_v = A_v h_2 \Delta v \tag{1.70}$$

$$\int_{CD} \vec{A} \cdot d\vec{l} = - \left( A_v h_2 \Delta v + \frac{\partial}{\partial w} (A_v h_2 \Delta v) \Delta w \right) \tag{1.71}$$

The negative sign is because of the fact that the direction of traversal reverses. Similarly,

$$\int_{BC} \vec{A} \cdot d\vec{l} = \left( A_w h_3 \Delta w + \frac{\partial}{\partial v} (A_w h_3 \Delta w) \Delta v \right) \tag{1.72}$$

$$\int_{DA} \vec{A} \cdot d\vec{l} = -A_w h_3 \Delta w \tag{1.73}$$

Adding the contribution from all components, we can write:

$$\oint_{C_1} \vec{A} \cdot d\vec{l} = \left( \frac{\partial}{\partial v} (A_w h_3) - \frac{\partial}{\partial w} (A_v h_2) \right) \Delta v \Delta w \tag{1.74}$$

Therefore,  $(\nabla \times \vec{A}) \cdot \hat{a}_u = \frac{\oint_{C_1} \vec{A} \cdot d\vec{l}}{h_2 h_3 \Delta v \Delta w} = \frac{1}{h_2 h_3} \left( \frac{\partial (h_3 A_w)}{\partial v} - \frac{\partial (h_2 A_v)}{\partial w} \right) \tag{1.75}$

In the same manner if we compute for  $(\nabla \times \vec{A}) \cdot \hat{a}_v$  and  $(\nabla \times \vec{A}) \cdot \hat{a}_w$  we can write,

$$\nabla \times \vec{A} = \frac{1}{h_2 h_3} \left( \frac{\partial(h_3 A_w)}{\partial v} - \frac{\partial(h_2 A_v)}{\partial w} \right) \hat{a}_u + \frac{1}{h_1 h_3} \left( \frac{\partial(h_1 A_u)}{\partial w} - \frac{\partial(h_3 A_w)}{\partial u} \right) \hat{a}_v + \frac{1}{h_1 h_2} \left( \frac{\partial(h_2 A_v)}{\partial u} - \frac{\partial(h_1 A_u)}{\partial v} \right) \hat{a}_w$$

.....(1.76)

This can be written as,

$$\nabla \times \vec{A} = \frac{1}{h_1 h_2 h_3} \begin{vmatrix} h_1 \hat{a}_u & h_2 \hat{a}_v & h_3 \hat{a}_w \\ \frac{\partial}{\partial u} & \frac{\partial}{\partial v} & \frac{\partial}{\partial w} \\ h_1 A_u & h_2 A_v & h_3 A_w \end{vmatrix} \dots\dots\dots(1.77)$$

$$\nabla \times \vec{A} = \begin{vmatrix} \hat{a}_x & \hat{a}_y & \hat{a}_z \\ \frac{\partial}{\partial x} & \frac{\partial}{\partial y} & \frac{\partial}{\partial z} \\ A_x & A_y & A_z \end{vmatrix} \dots\dots\dots(1.78)$$

In Cartesian coordinates:

$$\nabla \times \vec{A} = \frac{1}{\rho} \begin{vmatrix} \hat{a}_\rho & \rho \hat{a}_\phi & \hat{a}_z \\ \frac{\partial}{\partial \rho} & \frac{\partial}{\partial \phi} & \frac{\partial}{\partial z} \\ A_\rho & \rho A_\phi & A_z \end{vmatrix} \dots\dots\dots(1.79)$$

In Cylindrical coordinates,

$$\nabla \times \vec{A} = \frac{1}{r^2 \sin \theta} \begin{vmatrix} \hat{a}_r & r \hat{a}_\theta & r \sin \theta \hat{a}_\phi \\ \frac{\partial}{\partial r} & \frac{\partial}{\partial \theta} & \frac{\partial}{\partial \phi} \\ A_r & r A_\theta & r \sin \theta A_\phi \end{vmatrix} \dots\dots\dots(1.80)$$

In Spherical polar coordinates,

Curl operation exhibits the following properties:

- (i) *Curl of a vector field is another vector field.*
- (ii)  $\nabla \times (\vec{A} + \vec{B}) = \nabla \times \vec{A} + \nabla \times \vec{B}$
- (iii)  $\nabla \times (V \vec{A}) = \nabla V \times \vec{A} + V \nabla \times \vec{A}$
- (iv)  $\nabla \cdot (\nabla \times \vec{A}) = 0$
- (v)  $\nabla \times \nabla V = 0$
- (vi)  $\nabla \times (\vec{A} \times \vec{B}) = \vec{A} \nabla \cdot \vec{B} - \vec{B} \nabla \cdot \vec{A} + (\vec{B} \cdot \nabla) \vec{A} - (\vec{A} \cdot \nabla) \vec{B}$  .....(1.81)

**Stoke's theorem :**

It states that the circulation of a vector field  $\vec{A}$  around a closed path is equal to the integral of  $\nabla \times \vec{A}$  over the surface bounded by this path. It may be noted that this equality holds provided  $\vec{A}$  and  $\nabla \times \vec{A}$  are continuous on the surface.

i.e,

$$\oint_L \vec{A} \cdot d\vec{l} = \int_S \nabla \times \vec{A} \cdot d\vec{s} \dots\dots\dots(1.82)$$

**Proof:**Let us consider an area S that is subdivided into large number of cells as shown in the figure 1.21.

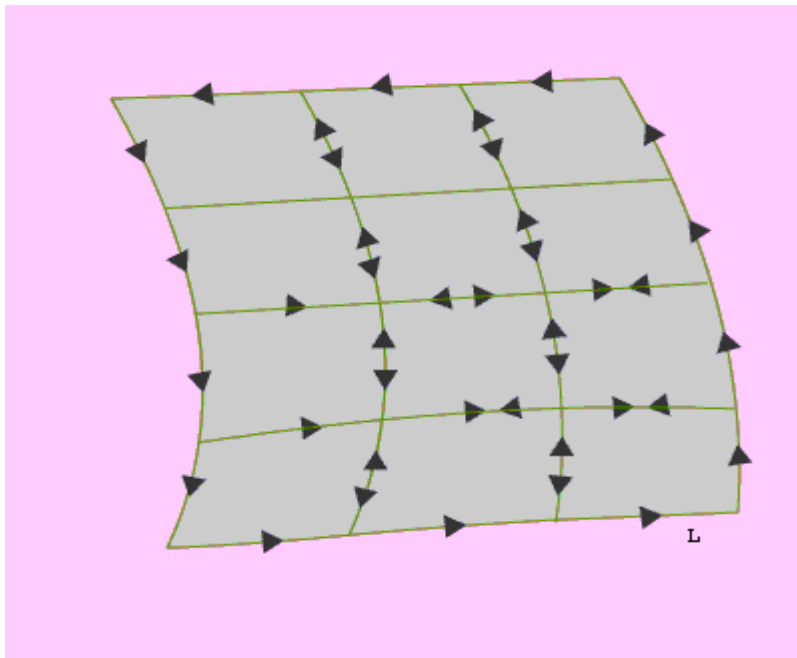

**Fig 1.21: Stokes theorem**

Let  $k^{th}$  cell has surface area  $\Delta S_k$  and is bounded path  $L_k$  while the total area is bounded by path  $L$ . As seen from the figure that if we evaluate the sum of the line integrals around the elementary areas, there is cancellation along every interior path and we are left the line integral along path  $L$ . Therefore we can write,

$$\oint_L \vec{A} \cdot d\vec{l} = \sum_k \oint_{L_k} \vec{A} \cdot d\vec{l} = \sum_k \frac{\oint_{L_k} \vec{A} \cdot d\vec{l}}{\Delta S_k} \Delta S_k \dots\dots\dots(1.83)$$

$$\text{As } \Delta S_k \rightarrow 0$$



$$\oint_L \vec{A} \cdot d\vec{l} = \int_S \nabla \times \vec{A} \cdot d\vec{s} \quad \dots\dots\dots(1.84)$$

which is the stoke's theorem.

### ASSIGNMENT PROBLEMS

1. In the Cartesian coordinate system; verify the following relations for a scalar function  $V$  and a vector function  $\vec{A}$

- $\nabla \times (\nabla V) = 0$
- $\nabla \cdot (\nabla \times \vec{A}) = 0$
- $\nabla \times (V\vec{A}) = V(\nabla \times \vec{A}) + (\nabla V) \times \vec{A}$

2. An electric field expressed in spherical polar coordinates is given by  $\vec{E} = \frac{9}{r^2} \hat{a}_r$ . Determine  $|\vec{E}|$  and  $E_y$  at a point  $P(-1, 2, -2)$ .

3. Evaluate  $\oint_S \frac{\sin \theta}{r_0^2} \hat{a}_r \cdot d\vec{S}$  over the surface of a sphere of radius  $r_0$  centered at the origin.

4. Find the divergence of the radial vector field given by  $f(\vec{r}) = \hat{a}_r r^n$ .

5. A vector function is defined by  $\vec{A} = xy^2 \hat{a}_x - yx^2 \hat{a}_y$ . Find  $\oint \vec{A} \cdot d\vec{l}$  around the contour shown in the figure P1.3. Evaluate  $\int (\nabla \times \vec{A}) \cdot d\vec{s}$  over the shaded area and verify that  $\oint \vec{A} \cdot d\vec{l} = \int (\nabla \times \vec{A}) \cdot d\vec{s}$

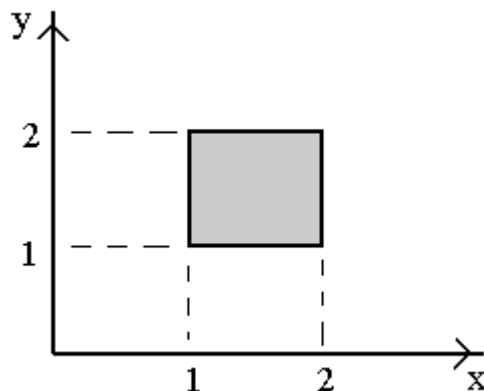

In the previous chapter we have covered the essential mathematical tools needed to study EM fields. We have already mentioned in the previous chapter that electric charge is a fundamental property of matter and charge exist in integral multiple of electronic charge. Electrostatics can be defined as the study of electric charges at rest. Electric fields have their sources in electric charges.

( Note: Almost all real electric fields vary to some extent with time. However, for many problems, the field variation is slow and the field may be considered as static. For some other cases spatial distribution is nearly same as for the static case even though the actual field may vary with time. Such cases are termed as quasi-static.)

In this chapter we first study two fundamental laws governing the electrostatic fields, viz, (1) Coulomb's Law and (2) Gauss's Law. Both these law have experimental basis. Coulomb's law is applicable in finding electric field due to any charge distribution, Gauss's law is easier to use when the distribution is symmetrical.

## Coulomb's Law

Coulomb's Law states that the force between two point charges  $Q_1$  and  $Q_2$  is directly proportional to the product of the charges and inversely proportional to the square of the distance between them.

Point charge is a hypothetical charge located at a single point in space. It is an idealised model of a particle having an electric charge.

$$F = \frac{kQ_1Q_2}{R^2}$$

Mathematically, , where  $k$  is the proportionality constant.

In SI units,  $Q_1$  and  $Q_2$  are expressed in Coulombs(C) and  $R$  is in meters.

$$k = \frac{1}{4\pi\epsilon_0}$$

Force  $F$  is in Newtons (N) and  $\epsilon_0$  is called the permittivity of free space.

(We are assuming the charges are in free space. If the charges are any other dielectric medium, we will use  $\epsilon = \epsilon_0 \epsilon_r$  instead where  $\epsilon_r$  is called the relative permittivity or the dielectric constant of the medium).

$$F = \frac{1}{4\pi\epsilon_0} \frac{Q_1Q_2}{R^2}$$

Therefore .....(2.1)

As shown in the Figure 2.1 let the position vectors of the point charges  $Q_1$  and  $Q_2$  are given by  $\vec{r}_1$  and  $\vec{r}_2$ . Let  $\vec{F}_{12}$  represent the force on  $Q_1$  due to charge  $Q_2$ .

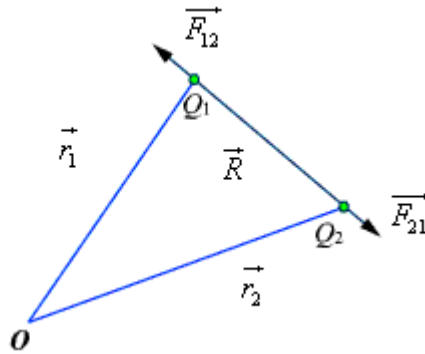

**Fig 2.1: Coulomb's Law**

The charges are separated by a distance of  $R = |\vec{r}_1 - \vec{r}_2| = |\vec{r}_2 - \vec{r}_1|$ . We define the unit vectors as

$$\hat{a}_{12} = \frac{(\vec{r}_2 - \vec{r}_1)}{R} \quad \text{and} \quad \hat{a}_{21} = \frac{(\vec{r}_1 - \vec{r}_2)}{R} \dots\dots\dots(2.2)$$

$\vec{F}_{12}$  can be defined as  $\vec{F}_{12} = \frac{Q_1 Q_2}{4\pi\epsilon_0 R^2} \hat{a}_{12} = \frac{Q_1 Q_2}{4\pi\epsilon_0 R^2} \frac{(\vec{r}_2 - \vec{r}_1)}{|\vec{r}_2 - \vec{r}_1|^3}$ . Similarly the force on  $Q_1$  due to charge  $Q_2$  can be calculated and if  $\vec{F}_{21}$  represents this force then we can write  $\vec{F}_{21} = -\vec{F}_{12}$

When we have a number of point charges, to determine the force on a particular charge due to all other charges, we apply principle of superposition. If we have  $N$  number of charges  $Q_1, Q_2, \dots, Q_N$  located respectively at the points represented by the position vectors  $\vec{r}_1, \vec{r}_2, \dots, \vec{r}_N$ , the force experienced by a charge  $Q$  located at  $\vec{r}$  is given by,

$$\vec{F} = \frac{Q}{4\pi\epsilon_0} \sum_{i=1}^N \frac{Q_i (\vec{r} - \vec{r}_i)}{|\vec{r} - \vec{r}_i|^3} \dots\dots\dots(2.3)$$

**Electric Field**

The electric field intensity or the electric field strength at a point is defined as the force per unit charge. That is

$$\vec{E} = \lim_{Q \rightarrow 0} \frac{\vec{F}}{Q} \quad \text{or,} \quad \vec{E} = \frac{\vec{F}}{Q} \dots\dots\dots(2.4)$$

The electric field intensity  $E$  at a point  $r$  (observation point) due a point charge  $Q$  located at  $\vec{r}'$  (source point) is given by:

$$\vec{E} = \frac{Q(\vec{r} - \vec{r}')}{4\pi\epsilon_0 |\vec{r} - \vec{r}'|^3} \dots\dots\dots(2.5)$$

For a collection of  $N$  point charges  $Q_1, Q_2, \dots, Q_N$  located at  $\vec{r}'_1, \vec{r}'_2, \dots, \vec{r}'_N$ , the electric field intensity at point  $\vec{r}$  is obtained as

$$\vec{E} = \frac{1}{4\pi\epsilon_0} \sum_{i=1}^N \frac{Q_i(\vec{r} - \vec{r}'_i)}{|\vec{r} - \vec{r}'_i|^3} \dots\dots\dots(2.6)$$

The expression (2.6) can be modified suitably to compute the electric field due to a continuous distribution of charges.

In figure 2.2 we consider a continuous volume distribution of charge  $\rho(t)$  in the region denoted as the source region.

For an elementary charge  $dQ = \rho(\vec{r}')dv'$ , i.e. considering this charge as point charge, we can write the field expression as:

$$d\vec{E} = \frac{dQ(\vec{r} - \vec{r}')}{4\pi\epsilon_0 |\vec{r} - \vec{r}'|^3} = \frac{\rho(\vec{r}')dv'(\vec{r} - \vec{r}')}{4\pi\epsilon_0 |\vec{r} - \vec{r}'|^3} \dots\dots\dots(2.7)$$

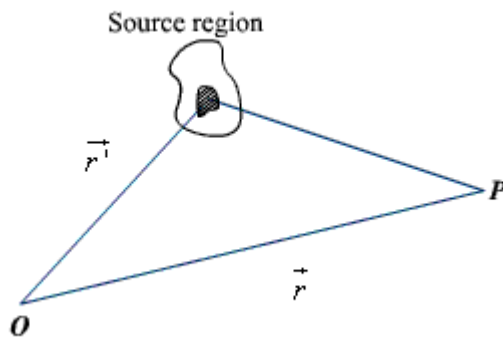

**Fig 2.2: Continuous Volume Distribution of Charge**

When this expression is integrated over the source region, we get the electric field at the point  $P$  due to this distribution of charges. Thus the expression for the electric field at  $P$  can be written as:

$$\vec{E}(\vec{r}) = \int_V \frac{\rho(\vec{r}')(\vec{r} - \vec{r}')}{4\pi\epsilon_0 |\vec{r} - \vec{r}'|^3} dV' \quad \dots\dots\dots(2.8)$$

Similar technique can be adopted when the charge distribution is in the form of a line charge density or a surface charge density.

$$\vec{E}(\vec{r}) = \int_L \frac{\rho_L(\vec{r}')(\vec{r} - \vec{r}')}{4\pi\epsilon_0 |\vec{r} - \vec{r}'|^3} dl' \quad \dots\dots\dots(2.9)$$

$$\vec{E}(\vec{r}) = \int_S \frac{\rho_s(\vec{r}')(\vec{r} - \vec{r}')}{4\pi\epsilon_0 |\vec{r} - \vec{r}'|^3} ds' \quad \dots\dots\dots(2.10)$$

### Electric flux density:

As stated earlier electric field intensity or simply 'Electric field' gives the strength of the field at a particular point. The electric field depends on the material media in which the field is being considered. The flux density vector is defined to be independent of the material media (as we'll see that it relates to the charge that is producing it). For a linear

isotropic medium under consideration; the flux density vector is defined as:

$$\vec{D} = \epsilon \vec{E} \quad \dots\dots\dots(2.11)$$

We define the electric flux  $\psi$  as

$$\psi = \int_S \vec{D} \cdot d\vec{s} \quad \dots\dots\dots(2.12)$$

**Gauss's Law:** Gauss's law is one of the fundamental laws of electromagnetism and it states that the total electric flux through a closed surface is equal to the total charge enclosed by the surface.

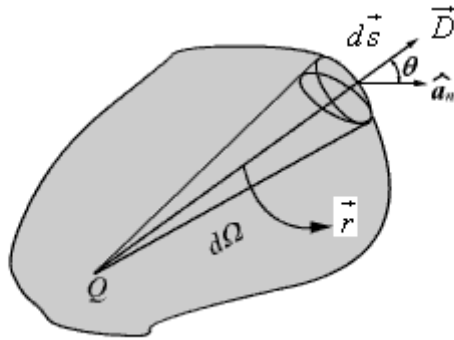

**Fig 2.3: Gauss's Law**

Let us consider a point charge  $Q$  located in an isotropic homogeneous medium of dielectric constant  $\epsilon$ . The flux density at a distance  $r$  on a surface enclosing the charge is given by

$$\vec{D} = \epsilon \vec{E} = \frac{Q}{4\pi r^2} \hat{a}_r \dots\dots\dots(2.13)$$

If we consider an elementary area  $ds$ , the amount of flux passing through the elementary area is given by

$$d\psi = \vec{D} \cdot ds = \frac{Q}{4\pi r^2} ds \cos \theta \dots\dots\dots(2.14)$$

But  $\frac{ds \cos \theta}{r^2} = d\Omega$ , is the elementary solid angle subtended by the area  $ds$  at the location of

$Q$ . Therefore we can write  $d\psi = \frac{Q}{4\pi} d\Omega$

$$\psi = \oint_S d\psi = \frac{Q}{4\pi} \oint_S d\Omega = Q$$

For a closed surface enclosing the charge, we can write

which can be seen to be same as what we have stated in the definition of Gauss's Law.

**Application of Gauss's Law**

Gauss's law is particularly useful in computing  $\vec{E}$  or  $\vec{D}$  where the charge distribution has some symmetry. We shall illustrate the application of Gauss's Law with some examples.

**1.An infinite line charge**

As the first example of illustration of use of Gauss's law, let consider the problem of determination of the electric field produced by an infinite line charge of density  $\rho_l$ C/m. Let us consider a line charge positioned along the  $z$ -axis as shown in Fig. 2.4(a) (next slide). Since

the line charge is assumed to be infinitely long, the electric field will be of the form as shown in Fig. 2.4(b) (next slide).

If we consider a close cylindrical surface as shown in Fig. 2.4(a), using Gauss's theorem we can write,

$$\rho_l l = Q = \oint_S \epsilon_0 \vec{E} \cdot d\vec{s} = \int_{S_1} \epsilon_0 \vec{E} \cdot d\vec{s} + \int_{S_2} \epsilon_0 \vec{E} \cdot d\vec{s} + \int_{S_3} \epsilon_0 \vec{E} \cdot d\vec{s} \dots\dots\dots(2.15)$$

Considering the fact that the unit normal vector to areas  $S_1$  and  $S_3$  are perpendicular to the electric field, the surface integrals for the top and bottom surfaces evaluates to zero. Hence we can write,  $\rho_l l = \epsilon_0 E \cdot 2\pi r l$

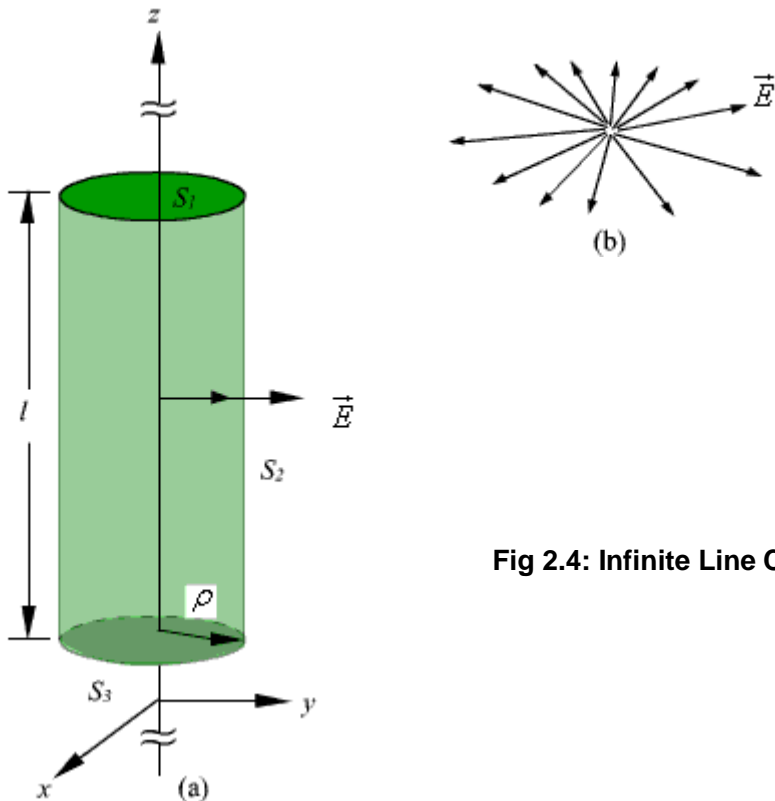

Fig 2.4: Infinite Line Charge

$$\vec{E} = \frac{\rho_l}{2\pi\epsilon_0 r} \hat{a}_r \dots\dots\dots(2.16)$$

## 2. Infinite Sheet of Charge

As a second example of application of Gauss's theorem, we consider an infinite charged sheet covering the  $x$ - $z$  plane as shown in figure 2.5.

Assuming a surface charge density of  $\rho_s$  for the infinite surface charge, if we consider a cylindrical volume having sides  $\Delta s$  placed symmetrically as shown in figure 5, we can write:

$$\oint_S \vec{D} \cdot d\vec{s} = 2D\Delta s = \rho_s \Delta s$$

$$\therefore \vec{E} = \frac{\rho_s}{2\epsilon_0} \hat{y} \quad \dots\dots\dots(2.17)$$

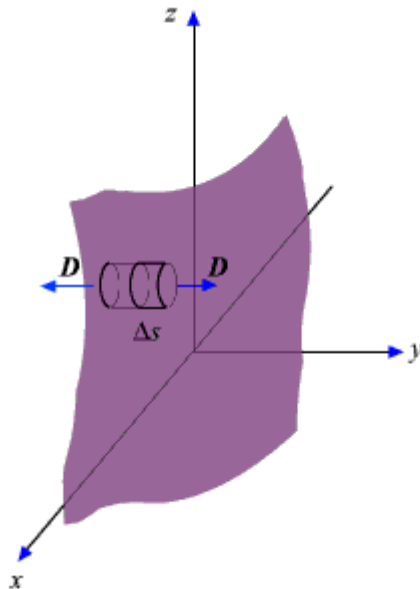

**Fig 2.5: Infinite Sheet of Charge**

It may be noted that the electric field strength is independent of distance. This is true for the infinite plane of charge; electric lines of force on either side of the charge will be perpendicular to the sheet and extend to infinity as parallel lines. As number of lines of force per unit area gives the strength of the field, the field becomes independent of distance. For a finite charge sheet, the field will be a function of distance.

## 3. Uniformly Charged Sphere

Let us consider a sphere of radius  $r_0$  having a uniform volume charge density of  $\rho_v$  C/m<sup>3</sup>. To determine  $\vec{D}$  everywhere, inside and outside the sphere, we construct Gaussian surfaces of radius  $r < r_0$  and  $r > r_0$  as shown in Fig. 2.6 (a) and Fig. 2.6(b).



For the region  $r \leq r_0$ ; the total enclosed charge will be

$$Q_{en} = \rho_v \frac{4}{3} \pi r^3 \dots\dots\dots(2.18)$$

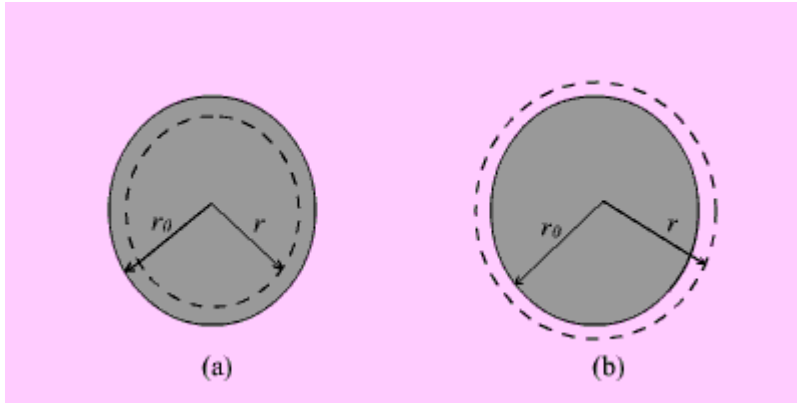

**Fig 2.6: Uniformly Charged Sphere**

By applying Gauss's theorem,

$$\oint_S \vec{D} \cdot d\vec{s} = \int_{\phi=0}^{2\pi} \int_{\theta=0}^{\pi} D_r r^2 \sin \theta d\theta d\phi = 4\pi r^2 D_r = Q_{en} \dots\dots\dots(2.19)$$

Therefore

$$\vec{D} = \frac{r}{3} \rho_v \hat{a}_r \quad 0 \leq r \leq r_0 \dots\dots\dots(2.20)$$

For the region  $r \geq r_0$ ; the total enclosed charge will be

$$Q_{en} = \rho_v \frac{4}{3} \pi r_0^3 \dots\dots\dots(2.21)$$

By applying Gauss's theorem,

$$\vec{D} = \frac{r_0^3}{3r^2} \rho_v \hat{a}_r \quad r \geq r_0 \dots\dots\dots(2.22)$$

\*\*\*\*\*

## Unit II Electrostatics-II

In this chapter we will discuss on the followings:

- Electrostatic Potential, Equipotential Surfaces
- Boundary Conditions for Static Electric Fields
  - Capacitance and Capacitors
    - Electrostatic Energy
  - Laplace's and Poisson's Equations
- Uniqueness of Electrostatic Solutions
  - Method of Images
- Solution of Boundary Value Problems in Different Coordinate Systems

### Electrostatic Potential and Equipotential Surfaces

*In the previous sections we have seen how the electric field intensity due to a charge or a charge distribution can be found using Coulomb's law or Gauss's law. Since a charge placed in the vicinity of another charge (or in other words in the field of other charge) experiences a force, the movement of the charge represents energy exchange. Electrostatic potential is related to the work done in carrying a charge from one point to the other in the presence of an electric field.*

Let us suppose that we wish to move a positive test charge  $\Delta q$  from a point  $P$  to another point  $Q$  as shown in the Fig. 2.8.

The force at any point along its path would cause the particle to accelerate and move it out of the region if unconstrained. Since we are dealing with an electrostatic case, a force equal to the negative of that acting on the charge is to be applied while  $\Delta q$  moves from  $P$  to  $Q$ . The work done by this external agent in moving the charge by a distance  $d\vec{l}$  is given by:

$$dW = -\Delta q \vec{E} \cdot d\vec{l} \dots\dots\dots(2.23)$$

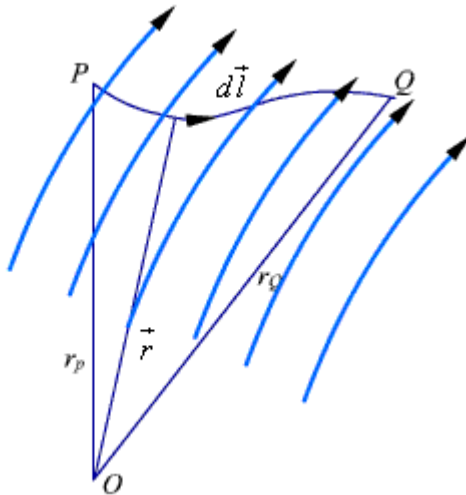

**Fig 2.8: Movement of Test Charge in Electric Field**

The negative sign accounts for the fact that work is done on the system by the external agent.

$$W = -\Delta q \int_P^Q \vec{E} \cdot d\vec{l} \dots\dots\dots(2.24)$$

The potential difference between two points  $P$  and  $Q$ ,  $V_{PQ}$ , is defined as the work done per unit charge, i.e.

$$V_{PQ} = \frac{W}{\Delta Q} = -\int_P^Q \vec{E} \cdot d\vec{l} \dots\dots\dots(2.25)$$

It may be noted that in moving a charge from the initial point to the final point if the potential difference is positive, there is a gain in potential energy in the movement, external agent performs the work against the field. If the sign of the potential difference is negative, work is done by the field.

We will see that the electrostatic system is conservative in that no net energy is exchanged if the test charge is moved about a closed path, i.e. returning to its initial position. Further, the potential difference between two points in an electrostatic field is a point function; it is independent of the path taken. The potential difference is measured in Joules/Coulomb which is referred to as **Volts**.

Let us consider a point charge  $Q$  as shown in the Fig. 2.9.

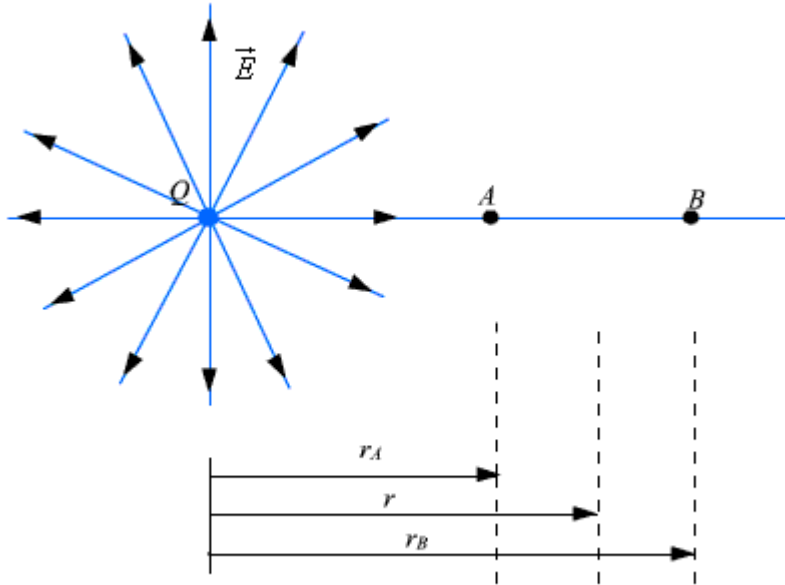

**Fig 2.9: Electrostatic Potential calculation for a point charge**

Further consider the two points  $A$  and  $B$  as shown in the Fig. 2.9. Considering the movement of a unit positive test charge from  $B$  to  $A$ , we can write an expression for the potential difference as:

$$V_{BA} = -\int_B^A \vec{E} \cdot d\vec{l} = -\int_{r_B}^{r_A} \frac{Q}{4\pi\epsilon_0 r^2} \hat{a}_r \cdot dr \hat{a}_r = \frac{Q}{4\pi\epsilon_0} \left[ \frac{1}{r_A} - \frac{1}{r_B} \right] = V_A - V_B \quad \dots\dots\dots(2.26)$$

It is customary to choose the potential to be zero at infinity. Thus potential at any point ( $r_A = r$ ) due to a point charge  $Q$  can be written as the amount of work done in bringing a unit positive charge from infinity to that point (i.e.  $r_B = 0$ ).

$$V = \frac{1}{4\pi\epsilon_0} \frac{Q}{r} \quad \dots\dots\dots(2.27)$$

Or, in other words,

$$V = - \int_{\infty}^r E \cdot dl \dots\dots\dots(2.28)$$

Let us now consider a situation where the point charge  $Q$  is not located at the origin as shown in Fig. 2.10.

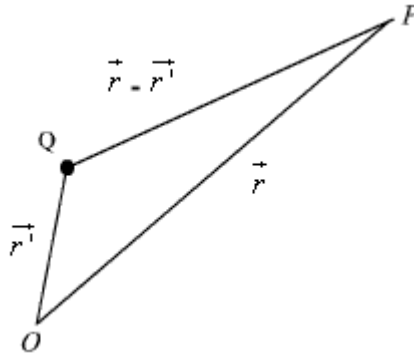

**Fig 2.10: Electrostatic Potential due a Displaced Charge**

The potential at a point  $P$  becomes

$$V(r) = \frac{Q}{4\pi\epsilon_0} \frac{1}{|r - r_1|} \dots\dots\dots(2.29)$$

So far we have considered the potential due to point charges only. As any other type of charge distribution can be considered to be consisting of point charges, the same basic ideas now can be extended to other types of charge distribution also.

Let us first consider  $N$  point charges  $Q_1, Q_2, \dots, Q_N$  located at points with position vectors  $\vec{r}_1, \vec{r}_2, \dots, \vec{r}_N$ . The potential at a point having position vector  $\vec{r}$  can be written as:

$$V(\vec{r}) = \frac{1}{4\pi\epsilon_0} \left( \frac{Q_1}{|\vec{r} - \vec{r}_1|} + \frac{Q_2}{|\vec{r} - \vec{r}_2|} + \dots + \frac{Q_N}{|\vec{r} - \vec{r}_N|} \right) \dots\dots\dots(2.30a)$$

or,

$$V(\vec{r}) = \frac{1}{4\pi\epsilon_0} \sum_{i=1}^N \frac{Q_i}{|\vec{r} - \vec{r}_i|} \dots\dots\dots(2.30b)$$

For continuous charge distribution, we replace point charges  $Q_n$  by corresponding charge elements  $\rho_l dl$  or  $\rho_s ds$  or  $\rho_v dv$  depending on whether the charge distribution is linear, surface or a volume charge distribution and the summation is replaced by an integral. With these modifications we can write:

$$V(\vec{r}) = \frac{1}{4\pi\epsilon_0} \int \frac{\rho_L(\vec{r}') dl'}{|\vec{r} - \vec{r}'|} \dots\dots\dots(2.31)$$

For line charge,

$$V(\vec{r}) = \frac{1}{4\pi\epsilon_0} \int \frac{\rho_S(\vec{r}') ds'}{|\vec{r} - \vec{r}'|} \dots\dots\dots(2.32)$$

For surface charge,

$$V(\vec{r}) = \frac{1}{4\pi\epsilon_0} \int \frac{\rho_V(\vec{r}') dv'}{|\vec{r} - \vec{r}'|} \dots\dots\dots(2.33)$$

For volume charge,

It may be noted here that the primed coordinates represent the source coordinates and the unprimed coordinates represent field point.

Further, in our discussion so far we have used the reference or zero potential at infinity. If any other point is chosen as reference, we can write:

$$V = \frac{Q}{4\pi\epsilon_0 r} + C \dots\dots\dots(2.34)$$

where  $C$  is a constant. In the same manner when potential is computed from a known electric field we can write:

$$V = -\int \vec{E} \cdot d\vec{l} + C \dots\dots\dots(2.35)$$

The potential difference is however independent of the choice of reference.

$$V_{AB} = V_B - V_A = -\int_A^B \vec{E} \cdot d\vec{l} = \frac{W}{Q} \dots\dots\dots(2.36)$$

We have mentioned that electrostatic field is a conservative field; the work done in moving a charge from one point to the other is independent of the path. Let us consider moving a charge from point  $P_1$  to  $P_2$  in one path and then from point  $P_2$  back to  $P_1$  over a different path. If the work done on the two paths were different, a net positive or negative amount of work would have been done when the body returns to its original position  $P_1$ . In a conservative field there is no mechanism for dissipating energy corresponding to any positive work neither any source is present from which energy could be absorbed in the case of negative work. Hence the question of different works in two paths is untenable, the work must have to be independent of path and depends on the initial and final positions.

Since the potential difference is independent of the paths taken,  $V_{AB} = -V_{BA}$ , and over a closed path,

$$V_{BA} + V_{AB} = \oint \vec{E} \cdot d\vec{l} = 0 \dots\dots\dots(2.37)$$

Applying Stokes's theorem, we can write:

$$\oint \vec{E} \cdot d\vec{l} = \int (\nabla \times \vec{E}) \cdot d\vec{s} = 0 \quad \dots\dots\dots(2.38)$$

from which it follows that for electrostatic field,

$$\nabla \times \vec{E} = 0 \quad \dots\dots\dots(2.39)$$

Any vector field  $\vec{A}$  that satisfies  $\nabla \times \vec{A} = 0$  is called an irrotational field.

From our definition of potential, we can write

$$dV = \frac{\partial V}{\partial x} dx + \frac{\partial V}{\partial y} dy + \frac{\partial V}{\partial z} dz = -\vec{E} \cdot d\vec{l}$$

$$\left( \frac{\partial V}{\partial x} \hat{a}_x + \frac{\partial V}{\partial y} \hat{a}_y + \frac{\partial V}{\partial z} \hat{a}_z \right) \cdot (dx \hat{a}_x + dy \hat{a}_y + dz \hat{a}_z) = -\vec{E} \cdot d\vec{l}$$

$$\nabla V \cdot d\vec{l} = -\vec{E} \cdot d\vec{l} \quad \dots\dots\dots(2.40)$$

from which we obtain,

$$\vec{E} = -\nabla V \quad \dots\dots\dots(2.41)$$

From the foregoing discussions we observe that the electric field strength at any point is the negative of the potential gradient at any point, negative sign shows that  $\vec{E}$  is directed from higher to lower values of  $V$ . This gives us another method of computing the electric field, i. e. if we know the potential function, the electric field may be computed. We may note here that that one scalar function  $V$  contain all the information that three components of  $\vec{E}$  carry, the same is possible because of the fact that three components of  $\vec{E}$  are interrelated by the relation  $\nabla \times \vec{E} = 0$ .

### Example: Electric Dipole

An electric dipole consists of two point charges of equal magnitude but of opposite sign and separated by a small distance.

As shown in figure 2.11, the dipole is formed by the two point charges  $Q$  and  $-Q$  separated by a distance  $d$ , the charges being placed symmetrically about the origin. Let us consider a point  $P$  at a distance  $r$ , where we are interested to find the field.

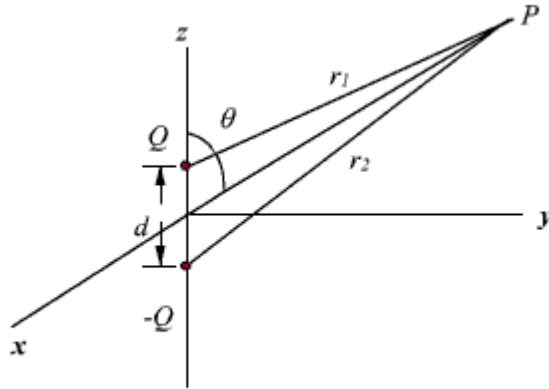

**Fig 2.11 : Electric Dipole**

The potential at P due to the dipole can be written as:

$$V = \frac{1}{4\pi\epsilon_0} \left[ \frac{Q}{r_1} - \frac{Q}{r_2} \right] = \frac{Q}{4\pi\epsilon_0} \left[ \frac{r_2 - r_1}{r_1 r_2} \right] \dots\dots\dots(2.42)$$

When  $r_1$  and  $r_2 \gg d$ , we can write  $r_2 - r_1 = 2 \times \frac{d}{2} \cos \theta = d \cos \theta$  and  $r_1 \cong r_2 \cong r$ .

Therefore,

$$V = \frac{Q}{4\pi\epsilon_0} \frac{d \cos \theta}{r^2} \dots\dots\dots(2.43)$$

We can write,

$$Qd \cos \theta = Qd \hat{a}_z \cdot \hat{a}_r \dots\dots\dots(2.44)$$

The quantity  $\vec{P} = Q\vec{d}$  is called the **dipole moment** of the electric dipole.

Hence the expression for the electric potential can now be written as:

$$V = \frac{\vec{P} \cdot \hat{a}_r}{4\pi\epsilon_0 r^2} \dots\dots\dots(2.45)$$

It may be noted that while potential of an isolated charge varies with distance as  $1/r$  that of an electric dipole varies as  $1/r^2$  with distance.



If the dipole is not centered at the origin, but the dipole center lies at  $\vec{r}'$ , the expression for the potential can be written as:

$$V = \frac{\vec{P} \cdot (\vec{r} - \vec{r}')}{4\pi\epsilon_0 |\vec{r} - \vec{r}'|^3} \dots\dots\dots(2.46)$$

The electric field for the dipole centered at the origin can be computed as

$$\begin{aligned} \vec{E} &= -\nabla V = -\left[ \frac{\partial V}{\partial r} \hat{a}_r + \frac{1}{r} \frac{\partial V}{\partial \theta} \hat{a}_\theta \right] \\ &= \frac{Qd \cos \theta}{2\pi\epsilon_0 r^3} \hat{a}_r + \frac{Qd \sin \theta}{4\pi\epsilon_0 r^3} \hat{a}_\theta \\ &= \frac{Qd}{4\pi\epsilon_0 r^3} (2 \cos \theta \hat{a}_r + \sin \theta \hat{a}_\theta) \\ \vec{E} &= \frac{\vec{P}}{4\pi\epsilon_0 r^3} (2 \cos \theta \hat{a}_r + \sin \theta \hat{a}_\theta) \dots\dots\dots(2.47) \end{aligned}$$

$\vec{P} = Q\vec{d}$  is the magnitude of the dipole moment. Once again we note that the electric field of electric dipole varies as  $1/r^3$  where as that of a point charge varies as  $1/r^2$ .

### **Equipotential Surfaces**

An equipotential surface refers to a surface where the potential is constant. The intersection of an equipotential surface with an plane surface results into a path called an equipotential line. No work is done in moving a charge from one point to the other along an equipotential line or surface.

In figure 2.12, the dashes lines show the equipotential lines for a positive point charge. By symmetry, the equipotential surfaces are spherical surfaces and the equipotential lines are circles. The solid lines show the flux lines or electric lines of force.

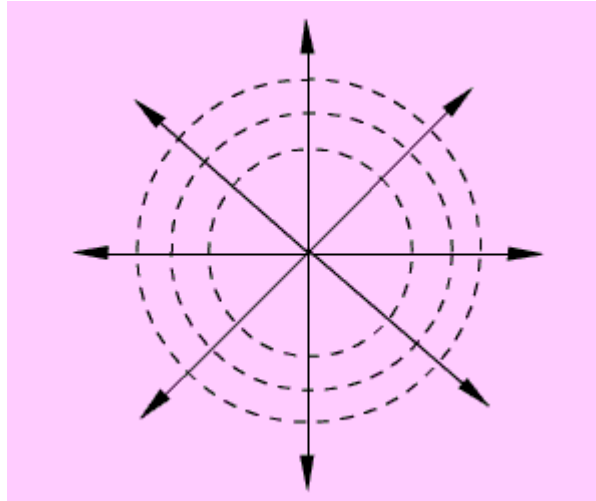

**Fig 2.12: Equipotential Lines for a Positive Point Charge**

Michael Faraday as a way of visualizing electric fields introduced flux lines. It may be seen that the electric flux lines and the equipotential lines are normal to each other.

In order to plot the equipotential lines for an electric dipole, we observe that for a given  $Q$  and  $d$ , a

constant  $V$  requires that  $\frac{\cos \theta}{r^2}$  is a constant. From this we can write  $r = c_v \sqrt{\cos \theta}$  to be the equation for an equipotential surface and a family of surfaces can be generated for various values of  $c_v$ . When plotted in 2-D this would give equipotential lines.

To determine the equation for the electric field lines, we note that field lines represent the direction of  $\vec{E}$  in space. Therefore,

$$d\vec{l} = k\vec{E}, k \text{ is a constant} \dots\dots\dots(2.48)$$

$$\hat{a}_r dr + r d\theta \hat{a}_\theta + \hat{a}_\phi r \sin \theta = k(\hat{a}_r E_r + \hat{a}_\theta E_\theta + \hat{a}_\phi E_\phi) = d\vec{l} \dots\dots\dots(2.49)$$

For the dipole under consideration  $E_\phi = 0$ , and therefore we can write,

$$\frac{dr}{E_r} = \frac{r d\theta}{E_\theta}$$

$$\frac{dr}{r} = \frac{2 \cos \theta d\theta}{\sin \theta} = \frac{2d(\sin \theta)}{\sin \theta} \dots\dots\dots(2.50)$$

Integrating the above expression we get  $r = c_e \sin^2 \theta$ , which gives the equations for electric flux lines. The representative plot ( $c_v = c$  assumed) of equipotential lines and flux lines for a dipole is shown in fig 2.13. Blue lines represent equipotential, red lines represent field lines.

## FIGURE MISSING

**Fig 2.13: Equipotential Lines and Flux Lines for a Dipole**

### Boundary conditions for Electrostatic fields

In our discussions so far we have considered the existence of electric field in the homogeneous medium. Practical electromagnetic problems often involve media with different physical properties. Determination of electric field for such problems requires the knowledge of the relations of field quantities at an interface between two media. The conditions that the fields must satisfy at the interface of two different media are referred to as **boundary conditions**.

In order to discuss the boundary conditions, we first consider the field behavior in some common material media.

In general, based on the electric properties, materials can be classified into three categories: conductors, semiconductors and insulators (dielectrics). In *conductor*, electrons in the outermost shells of the atoms are very loosely held and they migrate easily from one atom to the other. Most metals belong to this group. The electrons in the atoms of *insulators* or *dielectrics* remain confined to their orbits and under normal circumstances they are not liberated under the influence of an externally applied field. The electrical properties of *semiconductors* fall between those of conductors and insulators since semiconductors have very few numbers of free charges.

The parameter *conductivity* is used characterizes the macroscopic electrical property of a material medium. The notion of conductivity is more important in dealing with the current flow and hence the same will be considered in detail later on.

If some free charge is introduced inside a conductor, the charges will experience a force due to mutual repulsion and owing to the fact that they are free to move, the charges will appear on the surface. The charges will redistribute themselves in such a manner that the field within the conductor is zero. Therefore, under steady condition, inside a conductor  $\rho_v = 0$ .

From Gauss's theorem it follows that

$$\vec{E} = 0 \dots\dots\dots(2.51)$$

The surface charge distribution on a conductor depends on the shape of the conductor. The charges on the surface of the conductor will not be in equilibrium if there is a tangential component of the electric field is present, which would produce movement of the charges. Hence under static field conditions, tangential component of the electric field on the conductor surface is zero. The electric field on the surface of the conductor is normal everywhere to the surface. Since the tangential component of electric field is zero, the conductor surface is an equipotential surface. As  $\vec{E} = 0$  inside the conductor, the conductor as a whole has the same potential. We may further note that charges require a finite time to redistribute in a conductor. However, this time is very small  $\sim 10^{-19}$  sec for good conductor like copper.

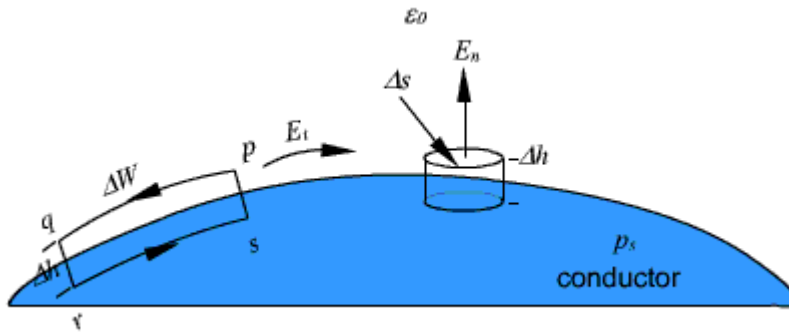

**Fig 2.14: Boundary Conditions for at the surface of a Conductor**

Let us now consider an interface between a conductor and free space as shown in the figure 2.14.

Let us consider the closed path  $pqrsp$  for which we can write,

$$\oint \vec{E} \cdot d\vec{l} = 0 \dots\dots\dots(2.52)$$

For  $\Delta h \rightarrow 0$  and noting that  $\vec{E}$  inside the conductor is zero, we can write

$$E_t \Delta w = 0 \dots\dots\dots(2.53)$$

$E_t$  is the tangential component of the field. Therefore we find that

$$E_t = 0 \dots\dots\dots(2.54)$$

In order to determine the normal component  $E_n$ , the normal component of  $\vec{E}$ , at the surface of the conductor, we consider a small cylindrical Gaussian surface as shown in the Fig.12.

Let  $\Delta s$  represent the area of the top and bottom faces and  $\Delta h$  represents the height of the cylinder. Once again, as  $\Delta h \rightarrow 0$ , we approach the surface of the conductor. Since  $\vec{E} = 0$  inside the conductor is zero,

$$\epsilon_0 \oint \vec{E} \cdot d\vec{s} = \epsilon_0 E_n \Delta s = \rho_s \Delta s \dots\dots\dots(2.55)$$

$$E_n = \frac{\rho_s}{\epsilon_0} \dots\dots\dots(2.56)$$

Therefore, we can summarize the boundary conditions at the surface of a conductor as:

$$E_t = 0 \dots\dots\dots(2.57)$$

$$E_x = \frac{\rho_s}{\epsilon_0} \dots\dots\dots(2.58)$$

### Behavior of dielectrics in static electric field: Polarization of dielectric

Here we briefly describe the behavior of dielectrics or insulators when placed in static electric field. Ideal dielectrics do not contain free charges. As we know, all material media are composed of atoms where a positively charged nucleus (diameter  $\sim 10^{-15}\text{m}$ ) is surrounded by negatively charged electrons (electron cloud has radius  $\sim 10^{-10}\text{m}$ ) moving around the nucleus. Molecules of dielectrics are neutral macroscopically; an externally applied field causes small displacement of the charge particles creating small electric dipoles. These induced dipole moments modify electric fields both inside and outside dielectric material.

Molecules of some dielectric materials possess permanent dipole moments even in the absence of an external applied field. Usually such molecules consist of two or more dissimilar atoms and are called *polar* molecules. A common example of such molecule is water molecule  $H_2O$ . In polar molecules the atoms do not arrange themselves to make the net dipole moment zero. However, in the absence of an external field, the molecules arrange themselves in a random manner so that net dipole moment over a volume becomes zero. Under the influence of an applied electric field, these dipoles tend to align themselves along the field as shown in figure 2.15. There are some materials that can exhibit net permanent dipole moment even in the absence of applied field. These materials are called *electrets* that are made by heating certain waxes or plastics in the presence of electric field. The applied field aligns the polarized molecules when the material is in the heated state and they are frozen to their new position when after the temperature is brought down to its normal temperatures. Permanent polarization remains without an externally applied field.

As a measure of intensity of polarization, polarization vector  $\vec{P}$  (in  $\text{C}/\text{m}^2$ ) is defined as:

$$\vec{P} = \lim_{\Delta v \rightarrow 0} \frac{\sum_{k=1}^{n\Delta v} \vec{P}_k}{\Delta v} \dots\dots\dots(2.59)$$

**FIGURE MISSING**

**Fig 2.15: Polarised Dielectric Medium**

$n$  being the number of molecules per unit volume i.e.  $\vec{P}$  is the dipole moment per unit volume. Let us now consider a dielectric material having polarization  $\vec{P}$  and compute the potential at an external point O due to an elementary dipole  $\vec{P} dv'$ .

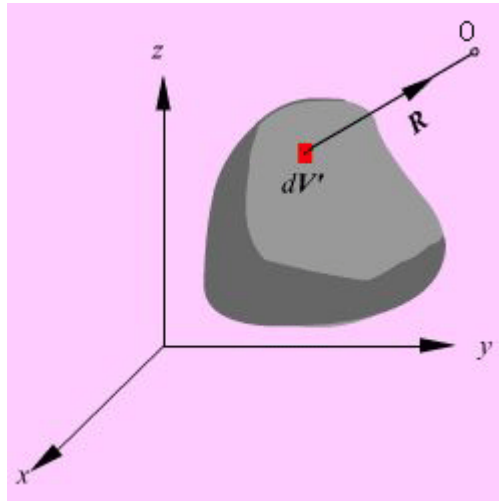

**Fig 2.16: Potential at an External Point due to an Elementary Dipole  $\vec{P} dv'$ .**

$$dV = \frac{\vec{P} dv' \cdot \hat{a}_R}{4\pi\epsilon_0 R^2} \dots\dots\dots(2.60)$$

With reference to the figure 2.16, we can write:

Therefore,

$$V = \int_V \frac{\vec{P} \cdot \hat{a}_R}{4\pi\epsilon_0 R^2} dv' \dots\dots\dots(2.61) \quad R = \left\{ (x - x')^2 + (y - y')^2 + (z - z')^2 \right\}^{1/2}$$

.....(2.62)

where  $x,y,z$  represent the coordinates of the external point  $O$  and  $x',y',z'$  are the coordinates of the source point.

From the expression of  $R$ , we can verify that

$$\nabla' \left( \frac{1}{R} \right) = \frac{\hat{a}_R}{R^2} \dots\dots\dots(2.63)$$

$$V = \frac{1}{4\pi\epsilon_0} \int_V \vec{P} \cdot \nabla' \left( \frac{1}{R} \right) dv' \dots\dots\dots(2.64)$$

Using the vector identity,  $\nabla' \cdot (f \vec{A}) = f \nabla' \cdot \vec{A} + \vec{A} \cdot \nabla' f$ , where  $f$  is a scalar quantity, we have,

$$V = \frac{1}{4\pi\epsilon_0} \left[ \int_V \nabla' \cdot \left( \frac{\vec{P}}{R} \right) dv' - \int_V \frac{\nabla' \cdot \vec{P}}{R} dv' \right] \dots\dots\dots(2.65)$$

Converting the first volume integral of the above expression to surface integral, we can write

$$V = \frac{1}{4\pi\epsilon_0} \oint_S \frac{\vec{P} \cdot \hat{a}'_n}{R} ds' + \frac{1}{4\pi\epsilon_0} \int_V \frac{(-\nabla \cdot \vec{P})}{R} dv' \quad \dots\dots\dots(2.66)$$

where  $\hat{a}'_n$  is the outward normal from the surface element  $ds'$  of the dielectric. From the above expression we find that the electric potential of a polarized dielectric may be found from the contribution of volume and surface charge distributions having densities

$$\rho_{ps} = \vec{P} \cdot \hat{a}_n \quad \dots\dots\dots(2.67)$$

$$\rho_{pv} = -\nabla \cdot \vec{P} \quad \dots\dots\dots(2.68)$$

These are referred to as polarisation or bound charge densities. Therefore we may replace a polarized dielectric by an equivalent polarization surface charge density and a polarization volume charge density. We recall that bound charges are those charges that are not free to move within the dielectric material, such charges are result of displacement that occurs on a molecular scale during polarization. The total bound charge on the surface is

$$\oint_S \rho_{ps} ds = \oint_S \vec{P} \cdot d\vec{s} \quad \dots\dots\dots(2.69)$$

The charge that remains inside the surface is

$$\int_V \rho_{pv} dv = \int_V -\nabla \cdot \vec{P} dv \quad \dots\dots\dots(2.70)$$

The total charge in the dielectric material is zero as

$$\oint_S \rho_{ps} ds + \int_V \rho_{pv} dv = \oint_S \vec{P} \cdot d\vec{s} + \int_V -\nabla \cdot \vec{P} dv = \int_V \nabla \cdot \vec{P} - \int_V \nabla \cdot \vec{P} = 0 \quad \dots\dots\dots(2.71)$$

If we now consider that the dielectric region containing charge density  $\rho_v$  the total volume charge density becomes

$$\rho_t = \rho_v + \rho_{pv} \quad \dots\dots\dots(2.72)$$

Since we have taken into account the effect of the bound charge density, we can write

$$\nabla \cdot \vec{E} = \frac{(\rho_v + \rho_{pv})}{\epsilon_0} \quad \dots\dots\dots(2.73)$$

Using the definition of  $\rho_{pv}$  we have

$$\nabla \cdot (\epsilon_0 \vec{E} + \vec{P}) = \rho_v \dots\dots\dots(2.74)$$

Therefore the electric flux density  $\vec{D} = \epsilon_0 \vec{E} + \vec{P}$

When the dielectric properties of the medium are linear and isotropic, polarisation is directly proportional to the applied field strength and

$$\vec{P} = \epsilon_0 \chi_e \vec{E} \dots\dots\dots(2.75)$$

is the electric susceptibility of the dielectric. Therefore,

$$\vec{D} = \epsilon_0 (1 + \chi_e) \vec{E} = \epsilon_0 \epsilon_r \vec{E} = \epsilon \vec{E} \dots\dots\dots(2.76)$$

$\epsilon_r = 1 + \chi_e$  is called relative permeability or the dielectric constant of the medium.  $\epsilon_0 \epsilon_r$  is called the absolute permittivity.

A dielectric medium is said to be linear when  $\chi_e$  is independent of  $\vec{E}$  and the medium is homogeneous if  $\chi_e$  is also independent of space coordinates. A linear homogeneous and isotropic medium is called a **simple medium** and for such medium the relative permittivity is a constant.

Dielectric constant  $\epsilon_r$  may be a function of space coordinates. For anisotropic materials, the dielectric constant is different in different directions of the electric field, D and E are related by a permittivity tensor which may be written as:

$$\begin{bmatrix} D_x \\ D_y \\ D_z \end{bmatrix} = \begin{bmatrix} \epsilon_{11} & \epsilon_{12} & \epsilon_{13} \\ \epsilon_{21} & \epsilon_{22} & \epsilon_{23} \\ \epsilon_{31} & \epsilon_{32} & \epsilon_{33} \end{bmatrix} \begin{bmatrix} E_x \\ E_y \\ E_z \end{bmatrix} \dots\dots\dots(2.77)$$

For crystals, the reference coordinates can be chosen along the principal axes, which make off diagonal elements of the permittivity matrix zero. Therefore, we have

$$\begin{bmatrix} D_x \\ D_y \\ D_z \end{bmatrix} = \begin{bmatrix} \epsilon_1 & 0 & 0 \\ 0 & \epsilon_2 & 0 \\ 0 & 0 & \epsilon_3 \end{bmatrix} \begin{bmatrix} E_x \\ E_y \\ E_z \end{bmatrix} \dots\dots\dots(2.78)$$

Media exhibiting such characteristics are called **biaxial**. Further, if  $\epsilon_1 = \epsilon_2$  then the medium is called **uniaxial**. It may be noted that for isotropic media,  $\epsilon_1 = \epsilon_2 = \epsilon_3$ .



Lossy dielectric materials are represented by a complex dielectric constant, the imaginary part of which provides the power loss in the medium and this is in general dependant on frequency.

Another phenomenon is of importance is **dielectric breakdown**. We observed that the applied electric field causes small displacement of bound charges in a dielectric material that results into polarization. Strong field can pull electrons completely out of the molecules. These electrons being accelerated under influence of electric field will collide with molecular lattice structure causing damage or distortion of material. For very strong fields, avalanche breakdown may also occur. The dielectric under such condition will become conducting.

The maximum electric field intensity a dielectric can withstand without breakdown is referred to as the **dielectric strength** of the material.

**Boundary Conditions for Electrostatic Fields:**

Let us consider the relationship among the field components that exist at the interface between two dielectrics as shown in the figure 2.17. The permittivity of the medium 1 and medium 2 are  $\epsilon_1$  and  $\epsilon_2$  respectively and the interface may also have a net charge density  $\rho_s$  Coulomb/m.

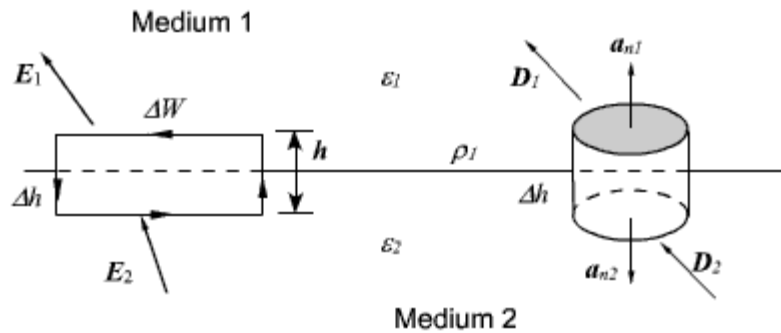

**Fig 2.17: Boundary Conditions at the interface between two dielectrics**

We can express the electric field in terms of the tangential and normal

$$\vec{E}_1 = \vec{E}_{1t} + \vec{E}_{1n}$$

$$\vec{E}_2 = \vec{E}_{2t} + \vec{E}_{2n} \dots\dots\dots(2.79)$$

where  $E_t$  and  $E_n$  are the tangential and normal components of the electric field respectively.

Let us assume that the closed path is very small so that over the elemental path length the variation of E can be neglected. Moreover very near to the interface,  $\Delta h \rightarrow 0$ . Therefore

$$\oint \vec{E} \cdot d\vec{l} = E_{1t} \Delta w - E_{2t} \Delta w + \frac{h}{2} (E_{1n} + E_{2n}) - \frac{h}{2} (E_{1n} + E_{2n}) = 0 \dots\dots\dots(2.80)$$

Thus, we have,

$$E_{1t} = E_{2t} \text{ or } \frac{D_{1t}}{\epsilon_1} = \frac{D_{2t}}{\epsilon_2} \text{ i.e. the tangential component of an electric field is continuous across the interface.}$$

For relating the flux density vectors on two sides of the interface we apply Gauss's law to a small pillbox volume as shown in the figure. Once again as  $\Delta h \rightarrow 0$ , we can write

$$\oint \vec{D} \cdot d\vec{s} = (\vec{D}_1 \cdot \hat{a}_{n2} + \vec{D}_2 \cdot \hat{a}_{n1}) \Delta s = \rho_s \Delta s \quad \dots\dots\dots(2.81a)$$

$$\text{i.e., } D_{1n} - D_{2n} = \rho_s \quad \dots\dots\dots(2.81b)$$

$$\text{i.e., } \epsilon_1 E_{1n} - \epsilon_2 E_{2n} = \rho_s \quad \dots\dots\dots(2.81c)$$

Thus we find that the **normal component of the flux density vector  $D$  is discontinuous across an interface by an amount of discontinuity equal to the surface charge density at the interface.**

### Example

Two further illustrate these points; let us consider an example, which involves the refraction of  $D$  or  $E$  at a charge free dielectric interface as shown in the figure 2.18.

Using the relationships we have just derived, we can write

$$E_{1t} = E_1 \sin \theta_1 = \frac{D_1}{\epsilon_1} \sin \theta_1 = E_{2t} = E_2 \sin \theta_2 = \frac{D_2}{\epsilon_2} \sin \theta_2 \quad \dots\dots\dots(2.82a)$$

$$D_{1n} = D_1 \cos \theta_1 = D_{2n} = D_2 \cos \theta_2 \quad \dots\dots\dots(2.82b)$$

In terms of flux density vectors,

$$\frac{D_1}{\epsilon_1} \sin \theta_1 = \frac{D_2}{\epsilon_2} \sin \theta_2 \quad \dots\dots\dots(2.83a)$$

$$D_1 \cos \theta_1 = D_2 \cos \theta_2 \quad \dots\dots\dots(2.83b)$$

$$\text{Therefore, } \frac{\tan \theta_1}{\tan \theta_2} = \frac{\epsilon_1}{\epsilon_2} = \frac{\epsilon_{r1}}{\epsilon_{r2}} \quad \dots\dots\dots(2.84)$$

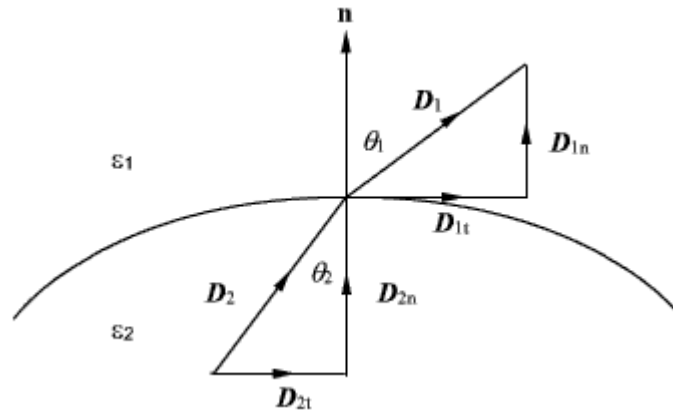

Fig 2.18: Refraction of D or E at a Charge Free Dielectric Interface

### Capacitance and Capacitors

We have already stated that a conductor in an electrostatic field is an Equipotential body and any charge given to such conductor will distribute themselves in such a manner that electric field inside the conductor vanishes. If an additional amount of charge is supplied to an isolated conductor at a given potential, this additional charge will increase the surface charge

density  $\rho_s$ . Since the potential of the conductor is given by  $V = \frac{1}{4\pi\epsilon_0} \int_S \frac{\rho_s ds'}{r}$ , the potential of the conductor will also increase maintaining the ratio  $\frac{Q}{V}$  same. Thus we can write  $C = \frac{Q}{V}$

where the constant of proportionality  $C$  is called the capacitance of the isolated conductor. SI unit of capacitance is Coulomb/ Volt also called Farad denoted by  $F$ . It can be seen that if  $V=1$ ,  $C = Q$ . Thus capacity of an isolated conductor can also be defined as the amount of charge in Coulomb required to raise the potential of the conductor by 1 Volt.

Of considerable interest in practice is a capacitor that consists of two (or more) conductors carrying equal and opposite charges and separated by some dielectric media or free space. The conductors may have arbitrary shapes. A two-conductor capacitor is shown in figure 2.19.

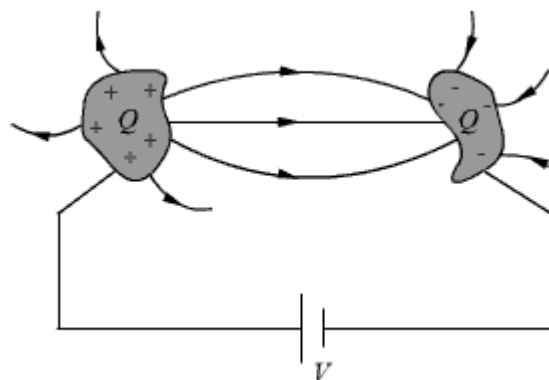

When a d-c voltage source is connected between the conductors, a charge transfer occurs which results into a positive charge on one conductor and negative charge on the other conductor. The conductors are equipotential surfaces and the field lines are perpendicular to the conductor surface. If  $V$  is the mean potential difference between the conductors, the

$$C = \frac{Q}{V}$$

capacitance is given by  $C = \frac{Q}{V}$ . Capacitance of a capacitor depends on the geometry of the conductor and the permittivity of the medium between them and does not depend on the charge or potential difference between conductors. The capacitance can be computed by

assuming  $Q$  (at the same time  $-Q$  on the other conductor), first determining  $\vec{E}$  using Gauss's

theorem and then determining  $V = -\int \vec{E} \cdot d\vec{l}$ . We illustrate this procedure by taking the example of a parallel plate capacitor.

**Example: Parallel plate capacitor**

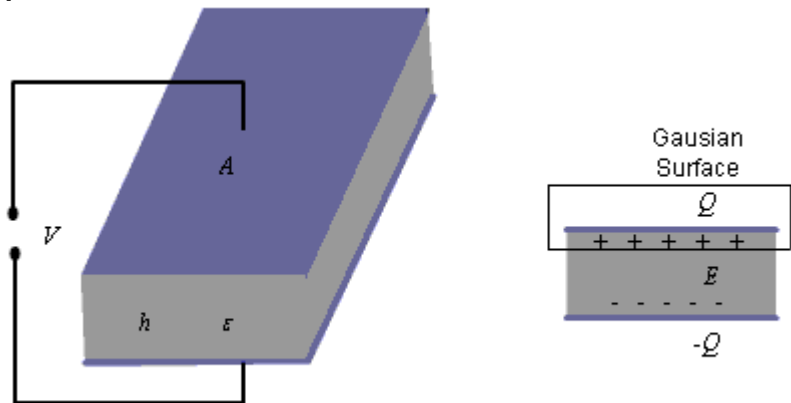

Fig 2.20: Parallel Plate Capacitor

For the parallel plate capacitor shown in the figure 2.20, let each plate has area  $A$  and a distance  $h$  separates the plates. A dielectric of permittivity  $\epsilon$  fills the region between the plates. The electric field lines are confined between the plates. We ignore the flux fringing at the edges of the plates and charges are assumed to be uniformly distributed over the

conducting plates with densities  $\rho_s$  and  $-\rho_s$ ,  $\rho_s = \frac{Q}{A}$ .

$$E = \frac{\rho_s}{\epsilon} = \frac{Q}{A\epsilon}$$

By Gauss's theorem we can write, .....(2.85)

As we have assumed  $\rho_s$  to be uniform and fringing of field is neglected, we see that  $E$  is

$$V = Eh = \frac{hQ}{\epsilon A}$$

constant in the region between the plates and therefore, we can write

$$C = \frac{Q}{V} = \epsilon \frac{A}{h}$$

for a parallel plate capacitor we have,

.....(2.86)

## Series and parallel Connection of capacitors

Capacitors are connected in various manners in electrical circuits; series and parallel connections are the two basic ways of connecting capacitors. We compute the equivalent capacitance for such connections.

**Series Case:** Series connection of two capacitors is shown in the figure 2.21. For this case we can write,

$$V = V_1 + V_2 = \frac{Q}{C_1} + \frac{Q}{C_2}$$

$$\frac{V}{Q} = \frac{1}{C_{eqs}} = \frac{1}{C_1} + \frac{1}{C_2} \dots\dots\dots(2.87)$$

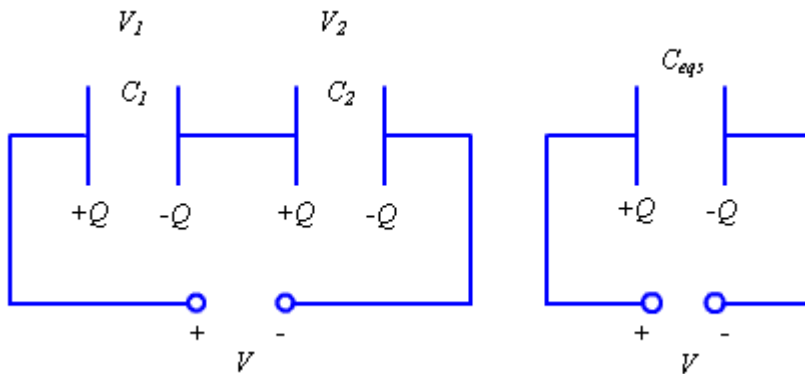

Fig 2.21: Series Connection of Capacitors

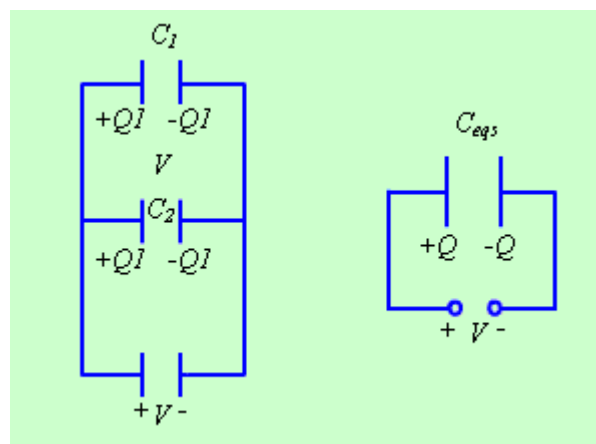

Fig 2.22: Parallel Connection of Capacitors

The same approach may be extended to more than two capacitors connected in series.

**Parallel Case:** For the parallel case, the voltages across the capacitors are the same.

The total charge  $Q = Q_1 + Q_2 = C_1V + C_2V$

$$C_{eq} = \frac{Q}{V} = C_1 + C_2 \dots\dots\dots(2.88)$$

Therefore,

**Electrostatic Energy and Energy Density**

We have stated that the electric potential at a point in an electric field is the amount of work required to bring a unit positive charge from infinity (reference of zero potential) to that point. To determine the energy that is present in an assembly of charges, let us first determine the amount of work required to assemble them. Let us consider a number of discrete charges  $Q_1, Q_2, \dots, Q_N$  are brought from infinity to their present position one by one. Since initially there is no field present, the amount of work done in bring  $Q_1$  is zero.  $Q_2$  is brought in the presence of the field of  $Q_1$ , the work done  $W_1 = Q_2V_{21}$  where  $V_{21}$  is the potential at the location of  $Q_2$  due to  $Q_1$ . Proceeding in this manner, we can write, the total work done

$$W = V_{21}Q_2 + (V_{31}Q_3 + V_{32}Q_3) + \dots\dots\dots + (V_{N1}Q_N + \dots\dots + V_{N(N-1)}Q_N) \dots\dots\dots(2.89)$$

Had the charges been brought in the reverse order,

$$W = (V_{1N}Q_1 + \dots\dots + V_{12}Q_1) + \dots\dots\dots + (V_{(N-2)(N-1)}Q_{N-2} + V_{(N-2)N}Q_{N-2}) + V_{(N-1)N}Q_{N-1} \dots\dots\dots(2.90)$$

Therefore,

$$2W = (V_{1N} + V_{1(N-1)} + \dots\dots + V_{12})Q_1 + (V_{2N} + V_{2(N-1)} + \dots\dots + V_{23} + V_{21})Q_2 \dots\dots \dots\dots + (V_{N1} + \dots\dots V_{N2} + V_{N(N-1)})Q_N \dots\dots\dots(2.91)$$

Here  $V_{IJ}$  represent voltage at the  $I^{th}$  charge location due to  $J^{th}$  charge. Therefore,

$$2W = V_{11}Q_1 + \dots\dots\dots + V_{NN}Q_N = \sum_{I=1}^N V_{II}Q_I$$

Or, 
$$W = \frac{1}{2} \sum_{I=1}^N V_{II}Q_I \dots\dots\dots(2.92)$$

If instead of discrete charges, we now have a distribution of charges over a volume  $v$  then we can write,

$$W = \frac{1}{2} \int_V V \rho_v dv \dots\dots\dots(2.93)$$

where  $\rho_v$  is the volume charge density and  $V$  represents the potential function.

Since,  $\rho_v = \nabla \cdot \vec{D}$ , we can write

$$W = \frac{1}{2} \int_V (\nabla \cdot \vec{D}) V dv \tag{2.94}$$

Using the vector identity,

$\nabla \cdot (V\vec{D}) = \vec{D} \cdot \nabla V + V \nabla \cdot \vec{D}$ , we can write

$$\begin{aligned} W &= \frac{1}{2} \int_V (\nabla \cdot (V\vec{D}) - \vec{D} \cdot \nabla V) dv \\ &= \frac{1}{2} \oint_S (V\vec{D}) \cdot d\vec{s} - \frac{1}{2} \int_V (\vec{D} \cdot \nabla V) dv \end{aligned} \tag{2.95}$$

In the expression  $\frac{1}{2} \oint_S (V\vec{D}) \cdot d\vec{s}$ , for point charges, since  $V$  varies as  $\frac{1}{r}$  and  $D$  varies as  $\frac{1}{r^2}$ , the term  $V\vec{D}$  varies as  $\frac{1}{r^3}$  while the area varies as  $r^2$ . Hence the integral term varies at least as  $\frac{1}{r}$  and as surface becomes large (i.e.  $r \rightarrow \infty$ ) the integral term tends to zero.

Thus the equation for  $W$  reduces to

$$W = -\frac{1}{2} \int_V (\vec{D} \cdot \nabla V) dv = \frac{1}{2} \int_V (\vec{D} \cdot \vec{E}) dv = \frac{1}{2} \int_V (\epsilon E^2) dv = \int_V w_e dv \tag{2.96}$$

$w_e = \frac{1}{2} \epsilon E^2$ , is called the energy density in the electrostatic field.

### Poisson's and Laplace's Equations

For electrostatic field, we have seen that

$$\begin{aligned} \nabla \cdot \vec{D} &= \rho_v \\ \vec{E} &= -\nabla V \end{aligned} \tag{2.97}$$

Form the above two equations we can write

$$\nabla \cdot (\epsilon \vec{E}) = \nabla \cdot (-\epsilon \nabla V) = \rho_v \quad \dots\dots\dots(2.98)$$

Using vector identity we can write,  $\epsilon \nabla \cdot \nabla V + \nabla V \cdot \nabla \epsilon = -\rho_v \quad \dots\dots\dots(2.99)$

For a simple homogeneous medium,  $\epsilon$  is constant and  $\nabla \epsilon = 0$ . Therefore,

$$\nabla \cdot \nabla V = \nabla^2 V = -\frac{\rho_v}{\epsilon} \quad \dots\dots\dots(2.100)$$

This equation is known as **Poisson's equation**. Here we have introduced a new operator,  $\nabla^2$  (del square), called the Laplacian operator. In Cartesian coordinates,

$$\nabla^2 V = \nabla \cdot \nabla V = \left( \frac{\partial}{\partial x} \hat{a}_x + \frac{\partial}{\partial y} \hat{a}_y + \frac{\partial}{\partial z} \hat{a}_z \right) \cdot \left( \frac{\partial V}{\partial x} \hat{a}_x + \frac{\partial V}{\partial y} \hat{a}_y + \frac{\partial V}{\partial z} \hat{a}_z \right) \quad \dots\dots\dots(2.101)$$

Therefore, in Cartesian coordinates, Poisson equation can be written as:

$$\frac{\partial^2 V}{\partial x^2} + \frac{\partial^2 V}{\partial y^2} + \frac{\partial^2 V}{\partial z^2} = -\frac{\rho_v}{\epsilon} \quad \dots\dots\dots(2.102)$$

In cylindrical coordinates,

$$\nabla^2 V = \frac{1}{r} \frac{\partial}{\partial r} \left( r \frac{\partial V}{\partial r} \right) + \frac{1}{r^2} \frac{\partial^2 V}{\partial \phi^2} + \frac{\partial^2 V}{\partial z^2} \quad \dots\dots\dots(2.103)$$

In spherical polar coordinate system,

$$\nabla^2 V = \frac{1}{r^2} \frac{\partial}{\partial r} \left( r^2 \frac{\partial V}{\partial r} \right) + \frac{1}{r^2 \sin \theta} \frac{\partial}{\partial \theta} \left( \sin \theta \frac{\partial V}{\partial \theta} \right) + \frac{1}{r^2 \sin^2 \theta} \frac{\partial^2 V}{\partial \phi^2} \quad \dots\dots\dots(2.104)$$

At points in simple media, where no free charge is present, Poisson's equation reduces to

$$\nabla^2 V = 0 \quad \dots\dots\dots(2.105)$$

which is known as Laplace's equation.

Laplace's and Poisson's equation are very useful for solving many practical electrostatic field problems where only the electrostatic conditions (potential and charge) at some boundaries are known and solution of electric field and potential is to be found throughout the volume. We shall consider such applications in the section where we deal with boundary value problems.



1. A charged ring of radius  $a$  carrying a charge of  $\rho_L$  C/m lies in the x-y plane with its centre at the origin and a charge  $Q$  C is placed at the point  $(0, 0, 2d)$ . Determine  $\rho_L$  in terms of  $Q$  and  $a$  so that a test charge placed at  $(0, 0, 2d)$  does not experience any force.
2. A semicircular ring of radius  $a$  lies in the free space and carries a charge density  $\rho_L$  C/m. Find the electric field at the centre of the semicircle.
3. Consider a uniform sphere of charge with charge density  $\rho_0$  and radius  $b$ , centered at the origin. Find the electric field at a distance  $r$  from the origin for the two cases:  $r < b$  and  $r > b$ . Sketch the strength of the electric field as function of  $r$ .

4. A spherical charge distribution is given by

$$\rho_v = \begin{cases} \rho_0(a^2 - r^2), & r \leq a \\ 0, & r > a \end{cases}$$

$a$  is the radius of the sphere. Find the following:

- i. The total charge.
  - ii.  $\vec{E}$  for  $r \leq a$  and  $r > a$ .
  - iii. The value of  $r$  where the  $\vec{E}$  becomes maximum.
5. With reference to the Figure 2.6 determine the potential and field at the point  $P(0, 0, h)$  if the shaded region contains uniform charge density  $\rho_s/m^2$ .

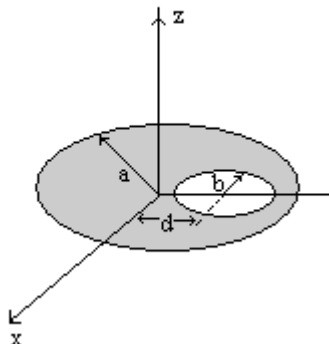

Figure 2.6

6. A capacitor consists of two coaxial metallic cylinders of length  $L$ , radius of the inner conductor  $a$  and that of outer conductor  $b$ . A dielectric material having dielectric

constant  $\epsilon_r = 3 + 2/\rho$ , where  $\rho$  is the radius, fills the space between the conductors. Determine the capacitance of the capacitor.

7. Determine whether the functions given below satisfy Laplace 's equation

i) 
$$V(x, y, z) = \frac{1}{\sqrt{x^2 + y^2 + z^2}}$$

ii) 
$$V(\rho, \phi, z) = \rho z \sin \phi + \rho^2$$

### Unit III Magnetostatics

In previous chapters we have seen that an electrostatic field is produced by static or stationary charges. The relationship of the steady magnetic field to its sources is much more complicated.

The source of steady magnetic field may be a permanent magnet, a direct current or an electric field changing with time. In this chapter we shall mainly consider the magnetic field produced by a direct current. The magnetic field produced due to time varying electric field will be discussed later. Historically, the link between the electric and magnetic field was established Oersted in 1820. Ampere and others extended the investigation of magnetic effect of electricity . There are two major laws governing the magnetostatic fields are:

- Biot-Savart Law
  
- Ampere's Law

Usually, the magnetic field intensity is represented by the vector  $\vec{H}$ . It is customary to represent the direction of the magnetic field intensity (or current) by a small circle with a dot or cross sign depending on whether the field (or current) is out of or into the page as shown in Fig. 4.1.

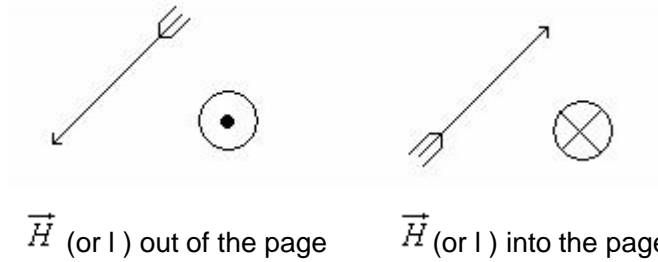

Fig. 4.1: Representation of magnetic field (or current)

### Biot- Savart Law

This law relates the magnetic field intensity  $dH$  produced at a point due to a differential current element  $Id\vec{l}$  as shown in Fig. 4.2.

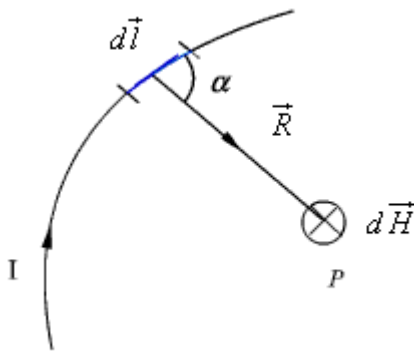

Fig. 4.2: Magnetic field intensity due to a current element

The magnetic field intensity  $d\vec{H}$  at P can be written as,

$$d\vec{H} = \frac{Id\vec{l} \times \hat{a}_R}{4\pi R^2} = \frac{Id\vec{l} \times \vec{R}}{4\pi R^3} \dots\dots\dots(4.1a)$$

$$dH = \frac{Idl \sin \alpha}{4\pi R^2} \dots\dots\dots(4.1b)$$

where  $R = |\vec{R}|$  is the distance of the current element from the point P.

Similar to different charge distributions, we can have different current distribution such as line current, surface current and volume current. These different types of current densities are shown in Fig. 4.3.

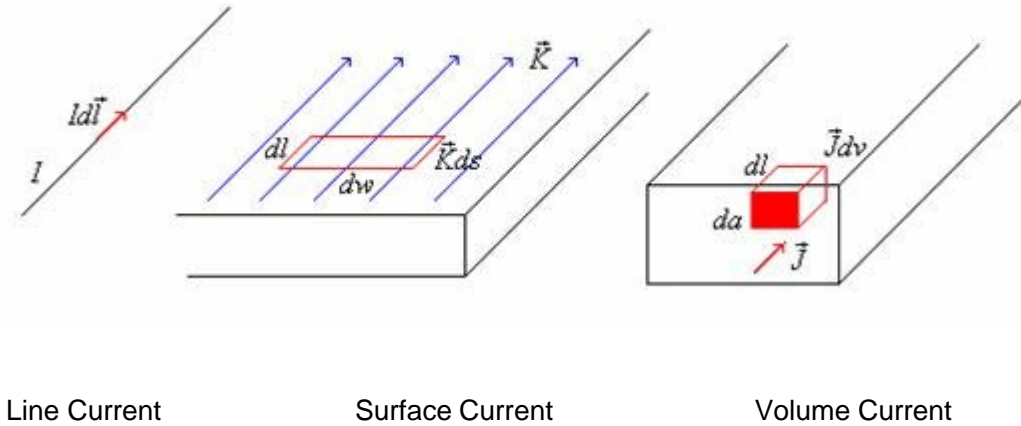

**Fig. 4.3: Different types of current distributions**

By denoting the surface current density as  $K$  (in amp/m) and volume current density as  $J$  (in amp/m<sup>2</sup>) we can write:

$$I d\vec{l} = \vec{K} ds = \vec{J} dv \dots\dots\dots(4.2)$$

( It may be noted that  $I = Kdw = Jda$  )

Employing Biot-Savart Law, we can now express the magnetic field intensity  $H$ . In terms of these current distributions.

$$\vec{H} = \int \frac{I d\vec{l} \times \vec{R}}{4\pi R^3} \dots\dots\dots \text{for line current} \dots\dots\dots(4.3a)$$

$$\vec{H} = \int \frac{K ds \times \vec{R}}{4\pi R^3} \dots\dots\dots \text{for surface current} \dots\dots\dots(4.3b)$$

$$\vec{H} = \int \frac{\vec{J} dv \times \vec{R}}{4\pi R^3} \dots\dots\dots \text{for volume current} \dots\dots\dots(4.3c)$$

To illustrate the application of Biot - Savart's Law, we consider the following example.

**Example 4.1:** We consider a finite length of a conductor carrying a current  $I$  placed along z-axis as shown in the Fig 4.4. We determine the magnetic field at point P due to this current carrying conductor.

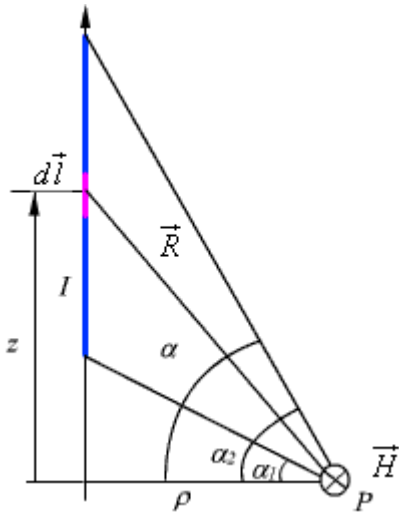

**Fig. 4.4: Field at a point P due to a finite length current carrying conductor**

With reference to Fig. 4.4, we find that

$$d\vec{l} = dz \hat{a}_z \text{ and } \vec{R} = \rho \hat{a}_\rho - z \hat{a}_z$$

.....(4.4)

Applying Biot - Savart's law for the current element  $\vec{I} d\vec{l}$

we can write,

$$d\vec{H} = \frac{I d\vec{l} \times \vec{R}}{4\pi R^3} = \frac{\rho dz \hat{a}_\phi}{4\pi[\rho^2 + z^2]^{3/2}}$$

.....(4.5)

Substituting  $\frac{z}{\rho} = \tan \alpha$  we can write,

$$\vec{H} = \int_{\alpha_1}^{\alpha_2} \frac{I}{4\pi} \frac{\rho^2 \sec^2 \alpha d\alpha}{\rho^3 \sec^3 \alpha} \hat{a}_\phi = \frac{I}{4\pi\rho} (\sin \alpha_2 - \sin \alpha_1) \hat{a}_\phi$$

.....(4.6)

We find that, for an infinitely long conductor carrying a current I,  $\alpha_2 = 90^\circ$  and  $\alpha_1 = -90^\circ$

Therefore,  $\vec{H} = \frac{I}{2\pi\rho} \hat{a}_\phi$  .....(4.7)

### Ampere's Circuital Law:

Ampere's circuital law states that the line integral of the magnetic field  $\vec{H}$  (circulation of H) around a closed path is the net current enclosed by this path. Mathematically,

$$\oint \vec{H} \cdot d\vec{l} = I_{enc} \quad \dots\dots\dots(4.8)$$

The total current  $I_{enc}$  can be written as,

$$I_{enc} = \int_S \vec{J} \cdot d\vec{s} \quad \dots\dots\dots(4.9)$$

By applying Stoke's theorem, we can write

$$\begin{aligned} \oint \vec{H} \cdot d\vec{l} &= \int_S \nabla \times \vec{H} \cdot d\vec{s} \\ \therefore \int_S \nabla \times \vec{H} \cdot d\vec{s} &= \int_S \vec{J} \cdot d\vec{s} \\ \therefore \nabla \times \vec{H} &= \vec{J} \quad \dots\dots\dots(4.10) \end{aligned}$$

which is the Ampere's law in the point form.

### Applications of Ampere's law:

We illustrate the application of Ampere's Law with some examples.

**Example 4.2:** We compute magnetic field due to an infinitely long thin current carrying conductor as shown in Fig. 4.5. Using Ampere's Law, we consider the close path to be a circle of radius  $\rho$  as shown in the Fig. 4.5.

If we consider a small current element  $Id\vec{l}(= Idz\hat{a}_z)$ ,  $d\vec{H}$  is perpendicular to the plane containing both  $d\vec{l}$  and  $\vec{R}(= \rho\hat{a}_\rho)$ . Therefore only component of  $\vec{H}$  that will be present is  $H_\phi$ , i.e.,  $\vec{H} = H_\phi\hat{a}_\phi$ .

By applying Ampere's law we can write,

$$\vec{H} = \frac{I}{2\pi\rho} \hat{a}_\phi \int_0^{2\pi} H_\phi \rho d\phi = H_\phi \rho 2\pi = I \quad \dots\dots\dots(4.11)$$

Therefore,  $\vec{H} = \frac{I}{2\pi\rho} \hat{a}_\phi$  which is same as equation (4.7)

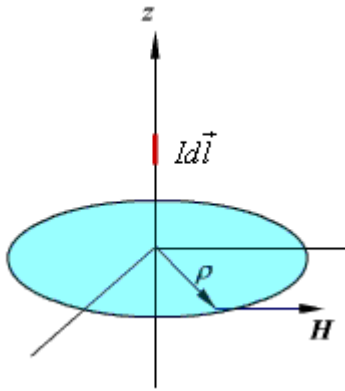

**Fig. 4.5: Magnetic field due to an infinite thin current carrying conductor**

**Example 4.3:** We consider the cross section of an infinitely long coaxial conductor, the inner conductor carrying a current  $I$  and outer conductor carrying current  $-I$  as shown in figure 4.6. We compute the magnetic field as a function of  $\rho$  as follows:

In the region  $0 \leq \rho \leq R_1$

$$I_{enc} = I \frac{\rho^2}{R_1^2} \dots\dots\dots(4.12)$$

$$H_\phi = \frac{I_{enc}}{2\pi\rho} = \frac{I\rho}{2\pi R_1^2} \dots\dots\dots(4.13)$$

In the region  $R_1 \leq \rho \leq R_2$

$$I_{enc} = I$$

$$H_\phi = \frac{I}{2\pi\rho} \dots\dots\dots(4.14)$$

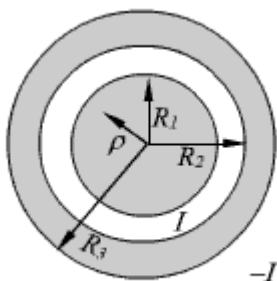

currents

In the region  $R_2 \leq \rho \leq R_3$

$$I_{enc} = I - I \frac{\rho^2 - R_2^2}{R_3^2 - R_2^2} \dots\dots\dots(4.15)$$

$$H_\phi = \frac{I}{2\pi\rho} \frac{R_3^2 - \rho^2}{R_3^2 - R_2^2} \dots\dots\dots(4.16)$$

In the region  $\rho > R_3$

$$I_{enc} = 0 \quad H_\phi = 0 \dots\dots\dots(4.17)$$

Magnetic Flux Density:

In simple matter, the magnetic flux density  $\vec{B}$  related to the magnetic field intensity  $\vec{H}$  as  $\vec{B} = \mu\vec{H}$  where  $\mu$  called the permeability. In particular when we consider the free space  $\vec{B} = \mu_0\vec{H}$  where  $\mu_0 = 4\pi \times 10^{-7}$  H/m is the permeability of the free space. Magnetic flux density is measured in terms of Wb/m<sup>2</sup>.

The magnetic flux density through a surface is given by:

$$\psi = \int_S \vec{B} \cdot d\vec{s} \quad \text{Wb} \dots\dots\dots(4.18)$$

In the case of electrostatic field, we have seen that if the surface is a closed surface, the net flux passing through the surface is equal to the charge enclosed by the surface. In case of magnetic field isolated magnetic charge (i. e. pole) does not exist. Magnetic poles always occur in pair (as N-S). For example, if we desire to have an isolated magnetic pole by dividing the magnetic bar successively into two, we end up with pieces each having north (N) and south (S) pole as shown in Fig. 4.7 (a). This process could be continued until the magnets are of atomic dimensions; still we will have N-S pair occurring together. This means that the magnetic poles cannot be isolated.



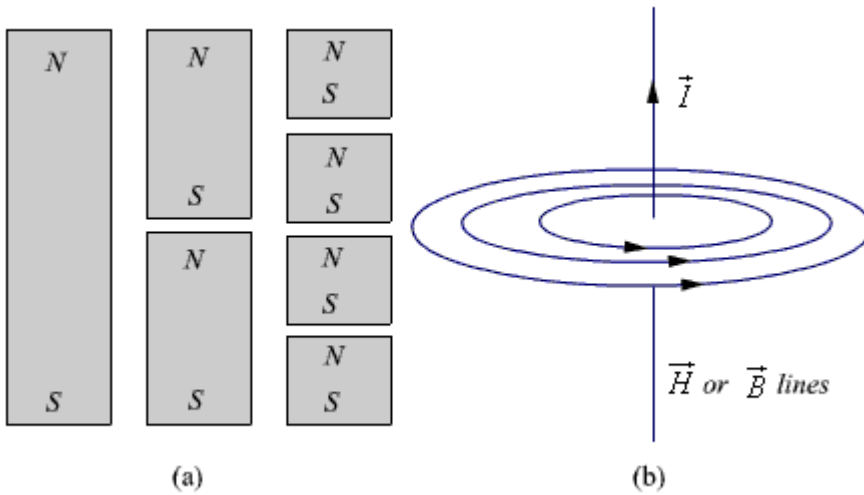

**Fig. 4.7: (a) Subdivision of a magnet (b) Magnetic field/ flux lines of a straight current carrying conductor**

Similarly if we consider the field/flux lines of a current carrying conductor as shown in Fig. 4.7 (b), we find that these lines are closed lines, that is, if we consider a closed surface, the number of flux lines that would leave the surface would be same as the number of flux lines that would enter the surface.

From our discussions above, it is evident that for magnetic field,

$$\oint_S \vec{B} \cdot d\vec{s} = 0 \quad \dots\dots\dots(4.19)$$

which is the Gauss's law for the magnetic field.

By applying divergence theorem, we can write:

$$\oint_S \vec{B} \cdot d\vec{s} = \int_V \nabla \cdot \vec{B} dv = 0$$

Hence,  $\nabla \cdot \vec{B} = 0 \quad \dots\dots\dots(4.20)$

which is the Gauss's law for the magnetic field in point form.

### **Magnetic Scalar and Vector Potentials:**

In studying electric field problems, we introduced the concept of electric potential that simplified the computation of electric fields for certain types of problems. In the same manner let us relate the magnetic field intensity to a **scalar magnetic potential** and write:

$$\vec{H} = -\nabla V_m \dots\dots\dots(4.21)$$

From Ampere's law , we know that

$$\nabla \times \vec{H} = \vec{J} \dots\dots\dots(4.22)$$

$$\text{Therefore, } \nabla \times (-\nabla V_m) = \vec{J} \dots\dots\dots(4.23)$$

But using vector identity,  $\nabla \times (\nabla V) = 0$  we find that  $\vec{H} = -\nabla V_m$  is valid only where  $\vec{J} = 0$ . Thus the scalar magnetic potential is defined only in the region where  $\vec{J} = 0$ . Moreover,  $V_m$  in general is not a single valued function of position.

This point can be illustrated as follows. Let us consider the cross section of a coaxial line as shown in fig 4.8.

In the region  $a < \rho < b$ ,  $\vec{J} = 0$  and  $\vec{H} = \frac{I}{2\pi\rho} \hat{a}_\phi$

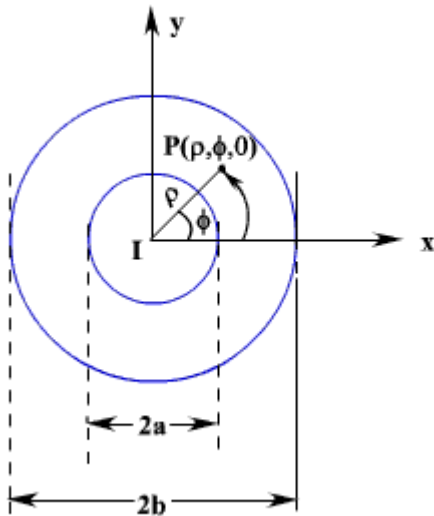

Fig. 4.8: Cross Section of a Coaxial Line

If  $V_m$  is the magnetic potential then,

$$\begin{aligned} -\nabla V_m &= -\frac{1}{\rho} \frac{\partial V_m}{\partial \phi} \\ &= \frac{I}{2\pi\rho} \end{aligned}$$

$$\therefore V_m = -\frac{I}{2\pi} \phi + c$$

If we set  $V_m = 0$  at  $\phi = 0$  then  $c=0$  and  $V_m = -\frac{I}{2\pi} \phi$

$$\therefore \text{At } \phi = \phi_0 \quad V_m = -\frac{I}{2\pi} \phi_0$$

We observe that as we make a complete lap around the current carrying conductor, we reach  $\phi_0$  again but  $V_m$  this time becomes

$$V_m = -\frac{I}{2\pi} (\phi_0 + 2\pi)$$

We observe that value of  $V_m$  keeps changing as we complete additional laps to pass through the same point. We introduced  $V_m$  analogous to electrostatic potential  $V$ . But for static electric fields,  $\nabla \times \vec{E} = 0$  and  $\oint \vec{E} \cdot d\vec{l} = 0$ , whereas for steady magnetic field  $\nabla \times \vec{H} = \vec{J}$  wherever  $\vec{J} = 0$  but  $\oint \vec{H} \cdot d\vec{l} = I$  even if  $\vec{J} = 0$  along the path of integration.

We now introduce the **vector magnetic potential** which can be used in regions where current density may be zero or nonzero and the same can be easily extended to time varying cases. The use of vector magnetic potential provides elegant ways of solving EM field problems.

Since  $\nabla \cdot \vec{B} = 0$  and we have the vector identity that for any vector  $\vec{A}$ ,  $\nabla \cdot (\nabla \times \vec{A}) = 0$ , we can write  $\vec{B} = \nabla \times \vec{A}$ .

Here, the vector field  $\vec{A}$  is called the vector magnetic potential. Its SI unit is Wb/m. Thus if can find  $\vec{A}$  of a given current distribution,  $\vec{B}$  can be found from  $\vec{A}$  through a curl operation.

We have introduced the vector function  $\vec{A}$  and related its curl to  $\vec{B}$ . A vector function is defined fully in terms of its curl as well as divergence. The choice of  $\nabla \cdot \vec{A}$  is made as follows.

$$\nabla \times \nabla \times \vec{A} = \mu \nabla \times \vec{H} = \mu \vec{J} \quad \dots \dots \dots (4.24)$$

By using vector identity,  $\nabla \times \nabla \times \vec{A} = \nabla(\nabla \cdot \vec{A}) - \nabla^2 \vec{A} \quad \dots \dots \dots (4.25)$

$$\nabla(\nabla \cdot \vec{A}) - \nabla^2 \vec{A} = \mu \vec{J} \quad \dots \dots \dots (4.26)$$

Great deal of simplification can be achieved if we choose  $\nabla \cdot \vec{A} = 0$ .

Putting  $\nabla \cdot \vec{A} = 0$ , we get  $\nabla^2 \vec{A} = -\mu \vec{J}$  which is vector poisson equation.

In Cartesian coordinates, the above equation can be written in terms of the components as

$$\nabla^2 A_x = -\mu J_x \dots\dots\dots(4.27a)$$

$$\nabla^2 A_y = -\mu J_y \dots\dots\dots(4.27b)$$

$$\nabla^2 A_z = -\mu J_z \dots\dots\dots(4.27c)$$

The form of all the above equation is same as that of

$$\nabla^2 V = -\frac{\rho}{\epsilon} \dots\dots\dots(4.28)$$

for which the solution is

$$V = \frac{1}{4\pi\epsilon} \int_V \frac{\rho}{R} dv', \quad R = |\vec{r} - \vec{r}'| \dots\dots\dots(4.29)$$

$$\nabla \cdot \vec{A} = \mu\epsilon \frac{\partial V}{\partial t}$$

In case of time varying fields we shall see that  $\nabla \cdot \vec{A} = \mu\epsilon \frac{\partial V}{\partial t}$ , which is known as Lorentz condition, V being the electric potential. Here we are dealing with static magnetic field, so  $\nabla \cdot \vec{A} = 0$ .

By comparison, we can write the solution for  $A_x$  as

$$A_x = \frac{\mu}{4\pi} \int_V \frac{J_x}{R} dv' \dots\dots\dots(4.30)$$

Computing similar solutions for other two components of the vector potential, the vector potential can be written as

$$\vec{A} = \frac{\mu}{4\pi} \int_V \frac{\vec{J}}{R} dv' \dots\dots\dots(4.31)$$

This equation enables us to find the vector potential at a given point because of a volume current density  $\vec{J}$ . Similarly for line or surface current density we can write

$$\vec{A} = \frac{\mu}{4\pi} \int_V \frac{I \vec{dl}'}{R} \dots\dots\dots(4.32)$$

$$\vec{A} = \frac{\mu}{4\pi} \int_V \frac{\vec{K}}{R} ds' \text{ respectively. } \dots\dots\dots(4.33)$$

The magnetic flux  $\psi$  through a given area S is given by

$$\psi = \int_S \vec{B} \cdot d\vec{s} \dots\dots\dots(4.34)$$

Substituting  $\vec{B} = \nabla \times \vec{A}$

$$\psi = \int_S \nabla \times \vec{A} \cdot d\vec{s} = \oint_C \vec{A} \cdot d\vec{l} \dots\dots\dots(4.35)$$

Vector potential thus have the physical significance that its integral around any closed path is equal to the magnetic flux passing through that path.

**Boundary Condition for Magnetic Fields:**

Similar to the boundary conditions in the electro static fields, here we will consider the behavior of  $\vec{B}$  and  $\vec{H}$  at the interface of two different media. In particular, we determine how the tangential and normal components of magnetic fields behave at the boundary of two regions having different permeabilities.

The figure 4.9 shows the interface between two media having permeabilities  $\mu_1$  and  $\mu_2$ ,  $\hat{a}_n$  being the normal vector from medium 2 to medium 1.

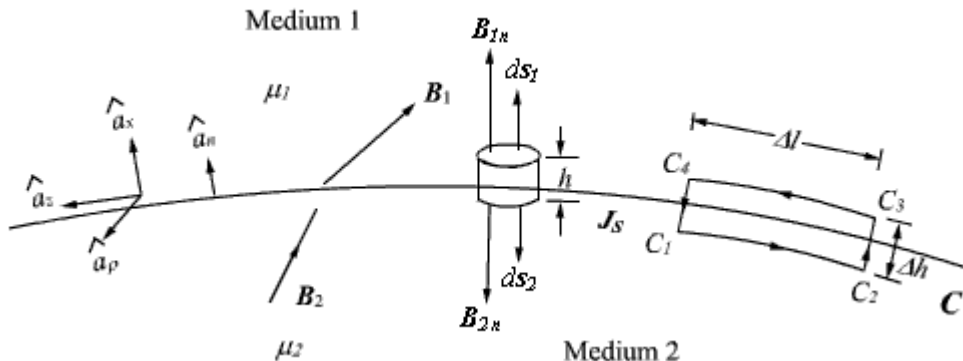

**Figure 4.9: Interface between two magnetic media**

To determine the condition for the normal component of the flux density vector  $\vec{B}$ , we consider a small pill box P with vanishingly small thickness  $h$  and having an elementary area

$\Delta S$  for the faces. Over the pill box, we can write

$$\oint_S \vec{B} \cdot d\vec{s} = 0 \quad \dots\dots\dots(4.36)$$

Since  $h \rightarrow 0$ , we can neglect the flux through the sidewall of the pill box.

$$\therefore \int_{\Delta S} \vec{B}_1 \cdot d\vec{S}_1 + \int_{\Delta S} \vec{B}_2 \cdot d\vec{S}_2 = 0 \quad \dots\dots\dots(4.37)$$

$$d\vec{S}_1 = dS \hat{a}_n \quad \text{and} \quad d\vec{S}_2 = dS \left( -\hat{a}_n \right) \quad \dots\dots\dots(4.38)$$

$$\therefore \int_{\Delta S} B_{1n} dS - \int_{\Delta S} B_{2n} dS = 0$$

where

$$B_{1n} = \vec{B}_1 \cdot \hat{a}_n \quad \text{and} \quad B_{2n} = \vec{B}_2 \cdot \hat{a}_n \quad \dots\dots\dots(4.39)$$

Since  $\Delta S$  is small, we can write

$$(B_{1n} - B_{2n}) \Delta S = 0$$

or,

$$B_{1n} = B_{2n} \quad \dots\dots\dots(4.40)$$

That is, the normal component of the magnetic flux density vector is continuous across the interface.

In vector form,

$$\hat{a}_n \cdot (\vec{B}_1 - \vec{B}_2) = 0 \quad \dots\dots\dots(4.41)$$

To determine the condition for the tangential component for the magnetic field, we consider a closed path C as shown in figure 4.8. By applying Ampere's law we can write

$$\oint \vec{H} \cdot d\vec{l} = I \quad \dots\dots\dots(4.42)$$

Since  $h \rightarrow 0$ ,

$$\int_{c_1-c_2} \vec{H} \cdot d\vec{l} + \int_{c_3-c_4} \vec{H} \cdot d\vec{l} = I \quad \dots\dots\dots(4.43)$$

We have shown in figure 4.8, a set of three unit vectors  $\hat{a}_n$ ,  $\hat{a}_t$  and  $\hat{a}_p$  such that they satisfy  $\hat{a}_t = \hat{a}_p \times \hat{a}_n$  (R.H. rule). Here  $\hat{a}_t$  is tangential to the interface and  $\hat{a}_p$  is the vector perpendicular to the surface enclosed by C at the interface

The above equation can be written as

$$\vec{H}_1 \cdot \Delta \hat{a}_t - \vec{H}_2 \cdot \Delta \hat{a}_t = I = J_s \Delta$$

or, 
$$H_{1t} - H_{2t} = J_s \dots\dots\dots(4.44)$$

i.e., tangential component of magnetic field component is discontinuous across the interface where a free surface current exists.

If  $J_s = 0$ , the tangential magnetic field is also continuous. If one of the medium is a perfect conductor  $J_s$  exists on the surface of the perfect conductor.

In vector form we can write,

$$\begin{aligned} (\vec{H}_1 - \vec{H}_2) \cdot \hat{a}_t \Delta \\ = (\vec{H}_1 - \vec{H}_2) \cdot (\hat{a}_p \times \hat{a}_n) \Delta \\ = J_s \Delta = \vec{J}_s \cdot \hat{a}_p \Delta \dots\dots\dots(4.45) \end{aligned}$$

Therefore,

$$\hat{a}_n \times (\vec{H}_1 - \vec{H}_2) = \vec{J}_s \dots\dots\dots(4.46)$$

#### ASSIGNMENT PROBLEMS

1. An infinitely long conductor carries a current  $I$  A is bent into an L shape and placed as shown in Fig. P.4.7. Determine the magnetic field intensity at a point P (0,0, a).

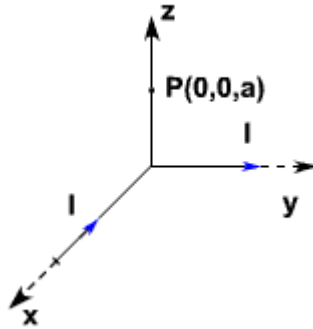

Figure P.4.7

2. Consider a long filamentary carrying a current  $IA$  in the  $+Z$  direction. Calculate the magnetic field intensity at point  $O(-a, a, 0)$ . Also determine the flux through this region described by  $\rho_1 \leq \rho \leq \rho_2, \phi = 0$  and  $-h \leq z \leq h$ .
3. A very long air cored solenoid is to produce an inductance  $0.1\text{H/m}$ . If the member of turns per unit length is  $1000/\text{m}$ . Determine the diameter of this turns of the solenoid.
4. Determine the force per unit length between two infinitely long conductor each carrying current  $IA$  and the conductor are separated by a distance  $d'$ .

## Unit IV Electrodynamic fields

### Introduction:

In our study of static fields so far, we have observed that static electric fields are produced by electric charges, static magnetic fields are produced by charges in motion or by steady current. Further, static electric field is a conservative field and has no curl, the static magnetic field is continuous and its divergence is zero. The fundamental relationships for static electric fields among the field quantities can be summarized as:

$$\nabla \times \vec{E} = 0 \quad (5.1a)$$

$$\nabla \cdot \vec{D} = \rho_v \quad (5.1b)$$

For a linear and isotropic medium,

$$\vec{D} = \epsilon \vec{E} \quad (5.1c)$$

Similarly for the magnetostatic case



$$\nabla \cdot \vec{B} = 0 \quad (5.2a)$$

$$\nabla \times \vec{H} = \vec{J} \quad (5.2b)$$

$$\vec{B} = \mu \vec{H} \quad (5.2c)$$

It can be seen that for static case, the electric field vectors  $\vec{E}$  and  $\vec{D}$  and magnetic field vectors  $\vec{B}$  and  $\vec{H}$  form separate pairs.

In this chapter we will consider the time varying scenario. In the time varying case we will observe that a changing magnetic field will produce a changing electric field and vice versa.

We begin our discussion with Faraday's Law of electromagnetic induction and then present the Maxwell's equations which form the foundation for the electromagnetic theory.

### Faraday's Law of electromagnetic Induction

Michael Faraday, in 1831 discovered experimentally that a current was induced in a conducting loop when the magnetic flux linking the loop changed. In terms of fields, we can say that a time varying magnetic field produces an electromotive force (emf) which causes a current in a closed circuit. The quantitative relation between the induced emf (the voltage that arises from conductors moving in a magnetic field or from changing magnetic fields) and the rate of change of flux linkage developed based on experimental observation is known as Faraday's law. Mathematically, the induced emf can be written as

$$\text{Emf} = - \frac{d\phi}{dt} \quad \text{Volts} \quad (5.3)$$

where  $\phi$  is the flux linkage over the closed path.

A non zero  $\frac{d\phi}{dt}$  may result due to any of the following:

- (a) time changing flux linkage a stationary closed path.
- (b) relative motion between a steady flux a closed path.
- (c) a combination of the above two cases.

The negative sign in equation (5.3) was introduced by Lenz in order to comply with the polarity of the induced emf. The negative sign implies that the induced emf will cause a current flow in the closed loop in such a direction so as to oppose the change in the linking magnetic flux which produces it. (It may be noted that as far as the induced emf is concerned, the closed path forming a loop does not necessarily have to be conductive).

If the closed path is in the form of  $N$  tightly wound turns of a coil, the change in the magnetic flux linking the coil induces an emf in each turn of the coil and total emf is the sum of the induced emfs of the individual turns, i.e.,

$$Emf = -N \frac{d\phi}{dt} \quad \text{Volts} \quad (5.4)$$

By defining the total flux linkage as

$$\lambda = N\phi \quad (5.5)$$

The emf can be written as

$$Emf = - \frac{d\lambda}{dt} \quad (5.6)$$

Continuing with equation (5.3), over a closed contour 'C' we can write

$$Emf = \oint_C \vec{E} \cdot d\vec{l} \quad (5.7)$$

where  $\vec{E}$  is the induced electric field on the conductor to sustain the current.

Further, total flux enclosed by the contour 'C' is given by

$$\phi = \int_S \vec{B} \cdot d\vec{s} \quad (5.8)$$

Where  $S$  is the surface for which 'C' is the contour.

From (5.7) and using (5.8) in (5.3) we can write

$$\oint_C \vec{E} \cdot d\vec{l} = - \frac{\partial}{\partial t} \oint_S \vec{B} \cdot d\vec{s} \quad (5.9)$$

By applying stokes theorem

$$\int_S \nabla \times \vec{E} \cdot d\vec{s} = - \int_S \frac{\partial \vec{B}}{\partial t} \cdot d\vec{s} \quad (5.10)$$

Therefore, we can write

$$\nabla \times \vec{E} = - \frac{\partial \vec{B}}{\partial t} \quad (5.11)$$

which is the Faraday's law in the point form

$$\frac{d\phi}{dt}$$

We have said that non zero  $\frac{d\phi}{dt}$  can be produced in a several ways. One particular case is when a time varying flux linking a stationary closed path induces an emf. The emf induced in a stationary closed path by a time varying magnetic field is called a transformer emf .

**Example: Ideal transformer**

As shown in figure 5.1, a transformer consists of two or more numbers of coils coupled magnetically through a common core. Let us consider an ideal transformer whose winding has zero resistance, the core having infinite permittivity and magnetic losses are zero.

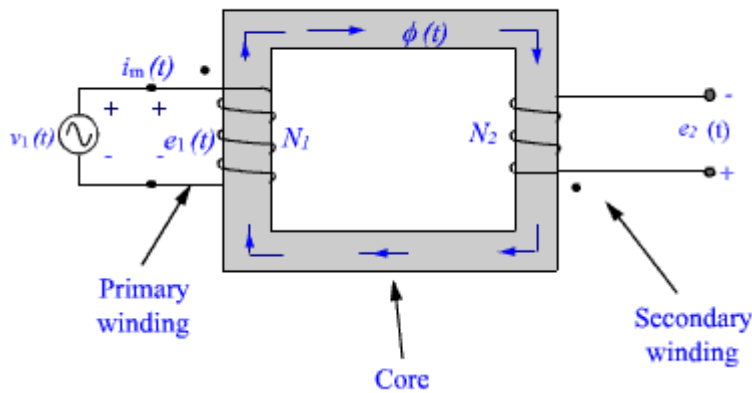

**Fig 5.1: Transformer with secondary open**

These assumptions ensure that the magnetization current under no load condition is vanishingly small and can be ignored. Further, all time varying flux produced by the primary winding will follow the magnetic path inside the core and link to the secondary coil without any leakage. If  $N_1$  and  $N_2$  are the number of turns in the primary and the secondary windings respectively, the induced emfs are

$$e_1 = N_1 \frac{d\phi}{dt} \tag{5.12a}$$

$$e_2 = N_2 \frac{d\phi}{dt} \tag{5.12b}$$

(The polarities are marked, hence negative sign is omitted. The induced emf is +ve at the dotted end of the winding.)

$$\therefore \frac{e_1}{e_2} = \frac{N_1}{N_2} \tag{5.13}$$

i.e., the ratio of the induced emfs in primary and secondary is equal to the ratio of their turns. Under ideal condition, the induced emf in either winding is equal to their voltage rating.

$$\frac{v_1}{v_2} = \frac{N_1}{N_2} = a \quad (5.14)$$

where 'a' is the transformation ratio. When the secondary winding is connected to a load, the current flows in the secondary, which produces a flux opposing the original flux. The net flux in the core decreases and induced emf will tend to decrease from the no load value. This causes the primary current to increase to nullify the decrease in the flux and induced emf. The current continues to increase till the flux in the core and the induced emfs are restored to the no load values. Thus the source supplies power to the primary winding and the secondary winding delivers the power to the load. Equating the powers

$$i_1 v_1 = i_2 v_2 \quad (5.15)$$

$$\frac{i_2}{i_1} = \frac{v_1}{v_2} = \frac{e_1}{e_2} = \frac{N_1}{N_2} \quad (5.16)$$

Further,

$$i_2 N_2 - i_1 N_1 = 0 \quad (5.17)$$

i.e., the net magnetomotive force (mmf) needed to excite the transformer is zero under ideal condition.

**Motional EMF:**

Let us consider a conductor moving in a steady magnetic field as shown in the fig 5.2.

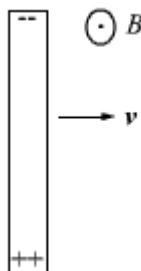

**Fig 5.2**

If a charge  $Q$  moves in a magnetic field  $\vec{B}$ , it experiences a force

$$\vec{F} = Q\vec{v} \times \vec{B} \quad (5.18)$$

This force will cause the electrons in the conductor to drift towards one end and leave the other end positively charged, thus creating a field and charge separation continuous until electric and magnetic forces balance and an equilibrium is reached very quickly, the net force on the moving conductor is zero.

$$\frac{\vec{F}}{Q} = \vec{v} \times \vec{B}$$

can be interpreted as an induced electric field which is called the motional electric field

$$\vec{E}_m = \vec{v} \times \vec{B} \quad (5.19)$$

If the moving conductor is a part of the closed circuit C, the generated emf around the circuit is  $\oint_C \vec{v} \times \vec{B} \cdot d\vec{l}$ . This emf is called the motional emf.

A classic example of motional emf is given in Additional Solved Example No.1 .

### Maxwell's Equation

Equation (5.1) and (5.2) gives the relationship among the field quantities in the static field. For time varying case, the relationship among the field vectors written as

$$\nabla \times \vec{E} = -\frac{\partial \vec{B}}{\partial t} \quad (5.20a)$$

$$\nabla \times \vec{H} = \vec{J} \quad (5.20b)$$

$$\nabla \cdot \vec{D} = \rho \quad (5.20c)$$

$$\nabla \cdot \vec{B} = 0 \quad (5.20d)$$

In addition, from the principle of conservation of charges we get the equation of continuity

$$\nabla \cdot \vec{J} = -\frac{\partial \rho}{\partial t} \quad (5.21)$$

The equation 5.20 (a) - (d) must be consistent with equation (5.21).

We observe that

$$\nabla \cdot \nabla \times \vec{H} = 0 = \nabla \cdot \vec{J} \quad (5.22)$$

Since  $\nabla \cdot \nabla \times \vec{A}$  is zero for any vector  $\vec{A}$ .

Thus  $\nabla \times \vec{H} = \vec{J}$  applies only for the static case i.e., for the scenario when  $\frac{\partial \rho}{\partial t} = 0$ .

A classic example for this is given below .

Suppose we are in the process of charging up a capacitor as shown in fig 5.3.

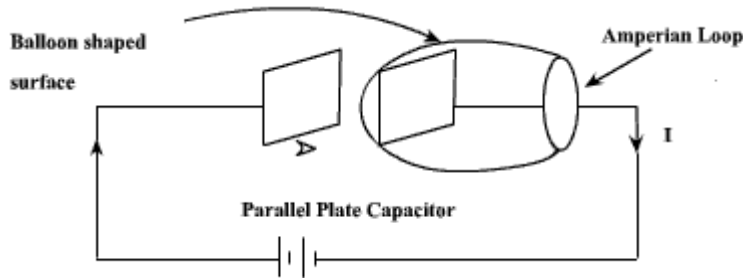

Fig 5.3

Let us apply the Ampere's Law for the Amperian loop shown in fig 5.3.  $I_{enc} = I$  is the total current passing through the loop. But if we draw a balloon shaped surface as in fig 5.3, no current passes through this surface and hence  $I_{enc} = 0$ . But for non steady currents such as this one, the concept of current enclosed by a loop is ill-defined since it depends on what surface you use. In fact Ampere's Law should also hold true for time varying case as well, then comes the idea of displacement current which will be introduced in the next few slides.

We can write for time varying case,

$$\begin{aligned}\nabla \cdot (\nabla \times \vec{H}) &= 0 = \nabla \cdot \vec{J} + \frac{\partial \rho}{\partial t} \\ &= \nabla \cdot \vec{J} + \frac{\partial}{\partial t} \nabla \cdot \vec{D} \\ &= \nabla \cdot \left( \vec{J} + \frac{\partial \vec{D}}{\partial t} \right)\end{aligned}\tag{5.23}$$

$$\therefore \nabla \times \vec{H} = \vec{J} + \frac{\partial \vec{D}}{\partial t}\tag{5.24}$$

The equation (5.24) is valid for static as well as for time varying case.

Equation (5.24) indicates that a time varying electric field will give rise to a magnetic field

even in the absence of  $\vec{J}$ . The term  $\frac{\partial \vec{D}}{\partial t}$  has a dimension of current densities  $\left(\frac{A}{m^2}\right)$  and is called the displacement current density.

Introduction of  $\frac{\partial \vec{D}}{\partial t}$  in  $\nabla \times \vec{H}$  equation is one of the major contributions of James Clerk Maxwell. The modified set of equations

$$\nabla \times \vec{E} = -\frac{\partial \vec{B}}{\partial t} \quad (5.25a)$$

$$\nabla \times \vec{H} = \vec{J} + \frac{\partial \vec{D}}{\partial t} \quad (5.25b)$$

$$\nabla \cdot \vec{D} = \rho \quad (5.25c)$$

$$\nabla \cdot \vec{B} = 0 \quad (5.25d)$$

is known as the Maxwell's equation and this set of equations apply in the time varying scenario, static fields are being a particular case  $\left(\frac{\partial}{\partial t} = 0\right)$ .

In the integral form

$$\oint_c \vec{E} \cdot d\vec{l} = -\int_s \frac{\partial \vec{B}}{\partial t} \cdot d\vec{S} \quad (5.26a)$$

$$\oint_c \vec{H} \cdot d\vec{l} = \int_s \left( \vec{J} + \frac{\partial \vec{D}}{\partial t} \right) \cdot d\vec{S} = I + \int_s \frac{\partial \vec{D}}{\partial t} \cdot d\vec{S} \quad (5.26b)$$

$$\int_v \nabla \cdot \vec{D} \, dv = \oint_s \vec{D} \cdot d\vec{S} = \int_v \rho \, dv \quad (5.26c)$$

$$\oint \vec{B} \cdot d\vec{S} = 0 \quad (5.26d)$$

The modification of Ampere's law by Maxwell has led to the development of a unified electromagnetic field theory. By introducing the displacement current term, Maxwell could predict the propagation of EM waves. Existence of EM waves was later demonstrated by Hertz experimentally which led to the new era of radio communication.

## Boundary Conditions for Electromagnetic fields

The differential forms of Maxwell's equations are used to solve for the field vectors provided the field quantities are single valued, bounded and continuous. At the media boundaries, the field vectors are discontinuous and their behaviors across the boundaries are governed by boundary conditions. The integral equations (eqn 5.26) are assumed to hold for regions containing discontinuous media. Boundary conditions can be derived by applying the Maxwell's equations in the integral form to small regions at the interface of the two media. The procedure is similar to those used for obtaining boundary conditions for static electric fields (chapter 2) and static magnetic fields (chapter 4). The boundary conditions are summarized as follows

$$\hat{a}_n \times (\vec{E}_1 - \vec{E}_2) = 0 \quad 5.27(a)$$

$$\hat{a}_n \cdot (\vec{D}_1 - \vec{D}_2) = \rho_s \quad 5.27(b)$$

$$\hat{a}_n \times (\vec{H}_1 - \vec{H}_2) = \vec{J}_s \quad 5.27(c)$$

$$\hat{a}_n \cdot (\vec{B}_1 - \vec{B}_2) = 0 \quad 5.27(d)$$

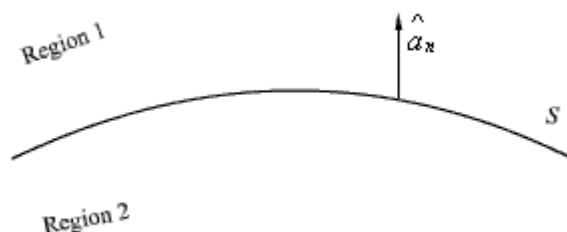

Fig 5.4

Equation 5.27 (a) says that tangential component of electric field is continuous across the interface while from 5.27 (c) we note that tangential component of the magnetic field is discontinuous by an amount equal to the surface current density. Similarly 5.27 (b) states that normal component of electric flux density vector  $\vec{D}$  is discontinuous across the interface by an amount equal to the surface current density while normal component of the magnetic flux density is continuous.

If one side of the interface, as shown in fig 5.4, is a perfect electric conductor, say region 2, a surface current  $\vec{J}_s$  can exist even though  $\vec{E}$  is zero as  $\sigma = \infty$ . Thus eqn 5.27(a) and (c) reduces to

$$\hat{a}_n \times \vec{H} = \vec{J}_s \quad (5.28(a))$$

$$\hat{a}_n \times \vec{E} = 0 \quad (5.28(b))$$

### Wave equation and their solution:

From equation 5.25 we can write the Maxwell's equations in the differential form as

$$\nabla \times \vec{H} = \vec{J} + \frac{\partial \vec{D}}{\partial t}$$

$$\nabla \times \vec{E} = -\frac{\partial \vec{B}}{\partial t}$$

$$\nabla \cdot \vec{D} = \rho$$

$$\nabla \cdot \vec{B} = 0$$



Let us consider a source free uniform medium having dielectric constant  $\epsilon$ , magnetic permeability  $\mu$  and conductivity  $\sigma$ . The above set of equations can be written as

$$\nabla \times \vec{H} = \sigma \vec{E} + \epsilon \frac{\partial \vec{E}}{\partial t} \quad (5.29(a))$$

$$\nabla \times \vec{E} = -\mu \frac{\partial \vec{H}}{\partial t} \quad (5.29(b))$$

$$\nabla \cdot \vec{E} = 0 \quad (5.29(c))$$

$$\nabla \cdot \vec{H} = 0 \quad (5.29(d))$$

Using the vector identity ,

$$\nabla \times \nabla \times \vec{A} = \nabla \cdot (\nabla \cdot \vec{A}) - \nabla^2 \vec{A}$$

We can write from 5.29(b)

$$\begin{aligned} \nabla \times \nabla \times \vec{E} &= \nabla \cdot (\nabla \cdot \vec{E}) - \nabla^2 \vec{E} \\ &= -\nabla \times \left( \mu \frac{\partial \vec{H}}{\partial t} \right) \end{aligned}$$

$$\text{or } \nabla \cdot (\nabla \cdot \vec{E}) - \nabla^2 \vec{E} = -\mu \frac{\partial}{\partial t} (\nabla \times \vec{H})$$

Substituting  $\nabla \times \vec{H}$  from 5.29(a)

$$\nabla \cdot (\nabla \cdot \vec{E}) - \nabla^2 \vec{E} = -\mu \frac{\partial}{\partial t} \left( \sigma \vec{E} + \epsilon \frac{\partial \vec{E}}{\partial t} \right)$$

But in source free medium  $\nabla \cdot \vec{E} = 0$  (eqn 5.29(c))

$$\nabla^2 \vec{E} = \mu \sigma \frac{\partial \vec{E}}{\partial t} + \mu \epsilon \frac{\partial^2 \vec{E}}{\partial t^2} \quad (5.30)$$

In the same manner for equation eqn 5.29(a)

$$\begin{aligned}
\nabla \times \nabla \times \vec{H} &= \nabla \cdot (\nabla \cdot \vec{H}) - \nabla^2 \vec{H} \\
&= \sigma (\nabla \times \vec{E}) + \varepsilon \frac{\partial}{\partial t} (\nabla \times \vec{E}) \\
&= \sigma \left( -\mu \frac{\partial \vec{H}}{\partial t} \right) + \varepsilon \frac{\partial}{\partial t} \left( -\mu \frac{\partial \vec{H}}{\partial t} \right)
\end{aligned}$$

Since  $\nabla \cdot \vec{H} = 0$  from eqn 5.29(d), we can write

$$\nabla^2 \vec{H} = \mu \sigma \left( \frac{\partial \vec{H}}{\partial t} \right) + \mu \varepsilon \left( \frac{\partial^2 \vec{H}}{\partial t^2} \right) \quad (5.31)$$

These two equations

$$\begin{aligned}
\nabla^2 \vec{E} &= \mu \sigma \frac{\partial \vec{E}}{\partial t} + \mu \varepsilon \frac{\partial^2 \vec{E}}{\partial t^2} \\
\nabla^2 \vec{H} &= \mu \sigma \left( \frac{\partial \vec{H}}{\partial t} \right) + \mu \varepsilon \left( \frac{\partial^2 \vec{H}}{\partial t^2} \right)
\end{aligned}$$

are known as wave equations.

It may be noted that the field components are functions of both space and time. For example, if we consider a Cartesian co ordinate system,  $\vec{E}$  and  $\vec{H}$  essentially represents  $\vec{E}(x, y, z, t)$  and  $\vec{H}(x, y, z, t)$ . For simplicity, we consider propagation in free space, i.e.  $\sigma = 0$ ,  $\mu = \mu_0$  and  $\varepsilon = \varepsilon_0$ . The wave eqn in equations 5.30 and 5.31 reduces to

$$\nabla^2 \vec{E} = \mu_0 \varepsilon_0 \left( \frac{\partial^2 \vec{E}}{\partial t^2} \right) \quad (5.32(a))$$

$$\nabla^2 \vec{H} = \mu_0 \varepsilon_0 \left( \frac{\partial^2 \vec{H}}{\partial t^2} \right) \quad (5.32(b))$$

Further simplifications can be made if we consider in Cartesian co ordinate system a special case where  $\vec{E}$  and  $\vec{H}$  are considered to be independent in two dimensions, say  $\vec{E}$  and  $\vec{H}$  are assumed to be independent of  $y$  and  $z$ . Such waves are called plane waves.

From eqn (5.32 (a)) we can write

$$\frac{\partial^2 \vec{E}}{\partial x^2} = \epsilon_0 \mu_0 \left( \frac{\partial^2 \vec{E}}{\partial t^2} \right)$$

The vector wave equation is equivalent to the three scalar equations

$$\frac{\partial^2 \vec{E}_x}{\partial x^2} = \epsilon_0 \mu_0 \left( \frac{\partial^2 \vec{E}_x}{\partial t^2} \right) \quad (5.33(a))$$

$$\frac{\partial^2 \vec{E}_y}{\partial x^2} = \epsilon_0 \mu_0 \left( \frac{\partial^2 \vec{E}_y}{\partial t^2} \right) \quad (5.33(b))$$

$$\frac{\partial^2 \vec{E}_z}{\partial x^2} = \epsilon_0 \mu_0 \left( \frac{\partial^2 \vec{E}_z}{\partial t^2} \right) \quad (5.33(c))$$

Since we have  $\nabla \cdot \vec{E} = 0$ ,

$$\therefore \frac{\partial \vec{E}_x}{\partial x} + \frac{\partial \vec{E}_y}{\partial y} + \frac{\partial \vec{E}_z}{\partial z} = 0 \quad (5.34)$$

As we have assumed that the field components are independent of  $y$  and  $z$  eqn (5.34) reduces to

$$\frac{\partial \vec{E}_x}{\partial x} = 0 \quad (5.35)$$

i.e. there is no variation of  $E_x$  in the  $x$  direction.

Further, from 5.33(a), we find that  $\frac{\partial \vec{E}_x}{\partial x} = 0$  implies  $\frac{\partial^2 \vec{E}_x}{\partial t^2} = 0$  which requires any three of the conditions to be satisfied: (i)  $E_x = 0$ , (ii)  $E_x = \text{constant}$ , (iii)  $E_x$  increasing uniformly with time.

A field component satisfying either of the last two conditions (i.e (ii) and (iii)) is not a part of a plane wave motion and hence  $E_x$  is taken to be equal to zero. Therefore, a uniform plane wave propagating in  $x$  direction does not have a field component ( $E$  or  $H$ ) acting along  $x$ .

Without loss of generality let us now consider a plane wave having  $E_y$  component only (Identical results can be obtained for  $E_z$  component) .

The equation involving such wave propagation is given by

$$\frac{\partial^2 \vec{E}_y}{\partial x^2} = \epsilon_0 \mu_0 \left( \frac{\partial^2 \vec{E}_y}{\partial t^2} \right) \quad (5.36)$$

The above equation has a solution of the form

$$E_y = f_1(x - v_0 t) + f_2(x + v_0 t) \quad (5.37)$$

where 
$$v_0 = \frac{1}{\sqrt{\mu_0 \epsilon_0}}$$

Thus equation (5.37) satisfies wave eqn (5.36) can be verified by substitution.

$f_1(x - v_0 t)$  corresponds to the wave traveling in the + x direction while  $f_2(x + v_0 t)$  corresponds to a wave traveling in the -x direction. The general solution of the wave eqn thus consists of two waves, one traveling away from the source and other traveling back towards the source. In the absence of any reflection, the second form of the eqn (5.37) is zero and the solution can be written as

$$E_y = f_1(x - v_0 t) \quad (5.38)$$

Such a wave motion is graphically shown in fig 5.5 at two instances of time  $t_1$  and  $t_2$ .

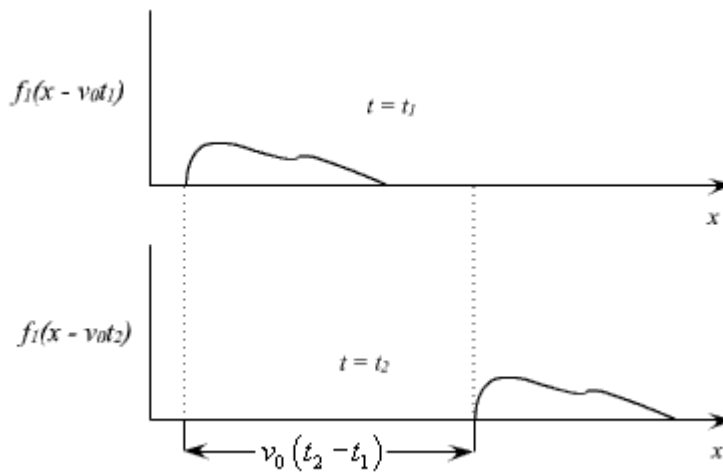

Fig 5.5 : Traveling wave in

**the + x direction**

Let us now consider the relationship between E and H components for the forward traveling wave.

Since  $\vec{E} = \hat{a}_y E_y = \hat{a}_y f_1(x - v_0 t)$  and there is no variation along y and z.

$$\nabla \times \vec{E} = \hat{a}_z \frac{\partial E_y}{\partial x}$$

Since only z component of  $\nabla \times \vec{E}$  exists, from (5.29(b))

$$\frac{\partial E_y}{\partial x} = -\mu_0 \frac{\partial H_z}{\partial t} \quad (5.39)$$

and from (5.29(a)) with  $\sigma = 0$ , only  $H_z$  component of magnetic field being present

$$\begin{aligned} \nabla \times \vec{H} &= -\hat{a}_y \frac{\partial H_z}{\partial x} \\ \therefore -\frac{\partial H_z}{\partial x} &= \epsilon_0 \frac{\partial E_y}{\partial t} \end{aligned} \quad (5.40)$$

Substituting  $E_y$  from (5.38)

$$\begin{aligned} \frac{\partial H_z}{\partial x} &= -\epsilon_0 \frac{\partial E_y}{\partial t} = \epsilon_0 v_0 f_1'(x - v_0 t) \\ \therefore \frac{\partial H_z}{\partial x} &= \epsilon_0 \frac{1}{\sqrt{\mu_0 \epsilon_0}} f_1'(x - v_0 t) \\ \therefore H_z &= \sqrt{\frac{\epsilon_0}{\mu_0}} \int f_1'(x - v_0 t) dx + c \\ &= \sqrt{\frac{\epsilon_0}{\mu_0}} \int \frac{\partial}{\partial x} f_1 dx + c \\ &= \sqrt{\frac{\epsilon_0}{\mu_0}} f_1 + c \\ H_z &= \sqrt{\frac{\epsilon_0}{\mu_0}} E_y + c \end{aligned}$$

The constant of integration means that a field independent of  $x$  may also exist. However, this field will not be a part of the wave motion.

$$\text{Hence } H_z = \sqrt{\frac{\epsilon_0}{\mu_0}} E_y \quad (5.41)$$

which relates the  $E$  and  $H$  components of the traveling wave.

$$z_0 = \frac{E_y}{H_z} = \sqrt{\frac{\mu_0}{\epsilon_0}} \cong 120\pi \text{ or } 377\Omega$$

$z_0 = \sqrt{\frac{\mu_0}{\epsilon_0}}$  is called the characteristic or intrinsic impedance of the free space

## ASSIGNMENT PROBLEMS

1. A rectangular loop of area  $a \times b \text{ m}^2$  rotates at  $\omega$  rad/s in a magnetic field of  $B$  Wb/m<sup>2</sup> normal to the axis of rotation. If the loop has  $N$  turns determine the induced voltage in the loop.
2. If the electric field component in a nonmagnetic dielectric medium is given by

$$\vec{E} = 501 \log(10^9 t - 8x) \hat{a}_y$$

determine the dielectric constant and the corresponding  $\vec{H}$ .

3. A vector field  $\vec{A}$  in phasor form is given by

$$\vec{A} = j5ye^{-\psi} \hat{a}_x$$

Express  $\vec{A}$  in instantaneous form.

## Unit V Electromagnetic waves

*In the previous chapter we introduced the equations pertaining to wave propagation and discussed how the wave equations are modified for time harmonic case. In this chapter we discuss in detail a particular form of electromagnetic wave propagation called 'plane waves'.*

### The Helmholtz Equation:

In source free linear isotropic medium, Maxwell equations in phasor form are,

$$\nabla \times \vec{E} = -j\omega\mu\vec{H} \quad \nabla \times \vec{E} = 0$$

$$\nabla \times \vec{H} = j\omega\epsilon\vec{E} \quad \nabla \times \vec{H} = 0$$

$$\therefore \nabla \times \nabla \times \vec{E} = \nabla(\nabla \times \vec{E}) - \nabla^2 \vec{E} = -j\omega\mu \nabla \times \vec{H}$$

$$\text{or, } -\nabla^2 \vec{E} = -j\omega\mu(j\omega\epsilon\vec{E})$$

$$\text{or, } \nabla^2 \vec{E} + \omega^2 \mu\epsilon \vec{E} = 0$$

$$\text{or, } \nabla^2 \vec{E} + k^2 \vec{E} = 0 \text{ where } k = \omega \sqrt{k\epsilon}$$

An identical equation can be derived for  $\vec{H}$ .

$$\text{i.e., } \nabla^2 \vec{H} + k^2 \vec{H} = 0$$

These equations

$$\left. \begin{aligned} \nabla^2 \vec{E} + k^2 \vec{E} &= 0 \dots\dots\dots (a) \\ \& \quad \nabla^2 \vec{H} + k^2 \vec{H} &= 0 \dots\dots\dots (b) \end{aligned} \right\} \dots\dots\dots (6.1)$$

are called homogeneous vector Helmholtz's equation.

$k = \omega \sqrt{\mu\epsilon}$  is called the wave number or propagation constant of the medium.

**Plane waves in Lossless medium:**

In a lossless medium,  $\epsilon$  and  $\mu$  are real numbers, so k is real.

In Cartesian coordinates each of the equations 6.1(a) and 6.1(b) are equivalent to three scalar Helmholtz's equations, one each in the components  $E_x, E_y$  and  $E_z$  or  $H_x, H_y, H_z$ .

For example if we consider  $E_x$  component we can write

$$\frac{\partial^2 E_x}{\partial x^2} + \frac{\partial^2 E_x}{\partial y^2} + \frac{\partial^2 E_x}{\partial z^2} + k^2 E_x = 0 \dots\dots\dots(6.2)$$

A uniform plane wave is a particular solution of Maxwell's equation assuming electric field (and magnetic field) has same magnitude and phase in infinite planes perpendicular to the direction of propagation. It may be noted that in the strict sense a uniform plane wave doesn't exist in practice as creation of such waves are possible with sources of infinite extent. However, at large distances from the source, the wavefront or the surface of the constant phase becomes almost spherical and a small portion of this large sphere can be considered to plane. The characteristics of plane waves are simple and useful for studying many practical scenarios.

Let us consider a plane wave which has only  $E_x$  component and propagating along z . Since the plane wave will have no variation along the plane perpendicular to z i.e., xy plane,

$$\frac{\partial E_x}{\partial x} = \frac{\partial E_x}{\partial y} = 0$$

. The Helmholtz's equation (6.2) reduces to,

$$\frac{d^2 E_x}{dz^2} + k^2 E_x = 0 \dots\dots\dots(6.3)$$

The solution to this equation can be written as

$$E_x(z) = E_x^+(z) + E_x^-(z) = E_0^+ e^{-jkz} + E_0^- e^{jkz} \dots\dots\dots(6.4)$$

$E_0^+$  &  $E_0^-$  are the amplitude constants (can be determined from boundary conditions).

In the time domain,  $\epsilon_x(z, t) = \text{Re}(E_x(z)e^{j\omega t})$

$$\epsilon_x(z, t) = E_0^+ \cos(\omega t - kz) + E_0^- \cos(\omega t + kz) \dots\dots\dots(6.5)$$

assuming  $E_0^+$  &  $E_0^-$  are real constants.

Here,  $\epsilon_x^+(z, t) = E_0^+ \cos(\omega t - \beta z)$  represents the forward traveling wave. The plot of  $\epsilon_x^+(z, t)$  for several values of  $t$  is shown in the Figure 6.1.

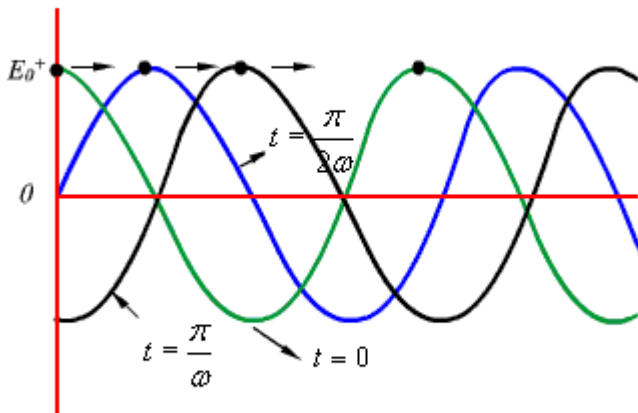

**Figure 6.1: Plane wave traveling in the + z direction**

As can be seen from the figure, at successive times, the wave travels in the +z direction.

If we fix our attention on a particular point or phase on the wave (as shown by the dot) i.e. ,  $\omega t - kz = \text{constant}$

Then we see that as  $t$  is increased to  $t + \Delta t$  ,  $z$  also should increase to  $z + \Delta z$  so that



$$\omega(t + \Delta t) - k(z + \Delta z) = \text{constant} = \omega t - \beta z$$

$$\text{Or, } \omega \Delta t = k \Delta z$$

$$\frac{\Delta z}{\Delta t} = \frac{\omega}{k}$$

$$\text{Or, } \Delta t = \frac{k}{\omega} \Delta z$$

When  $\Delta t \rightarrow 0$ ,

we write  $\lim_{\Delta t \rightarrow 0} \frac{\Delta z}{\Delta t} = \frac{dz}{dt} = \text{phase velocity } v_p$ .

$$\therefore v_p = \frac{\omega}{k} \dots\dots\dots(6.6)$$

If the medium in which the wave is propagating is free space i.e.,  $\epsilon = \epsilon_0, \mu = \mu_0$

$$\text{Then } v_p = \frac{\omega}{\omega \sqrt{\mu_0 \epsilon_0}} = \frac{1}{\sqrt{\mu_0 \epsilon_0}} = C$$

Where 'C' is the speed of light. That is plane EM wave travels in free space with the speed of light.

The wavelength  $\lambda$  is defined as the distance between two successive maxima (or minima or any other reference points).

$$\text{i.e., } (\omega t - kz) - [\omega t - k(z + \lambda)] = 2\pi$$

$$\text{or, } k\lambda = 2\pi$$

$$\lambda = \frac{2\pi}{k}$$

$$\text{or,}$$

$$k = \frac{\omega}{v_p}$$

Substituting

$$\lambda = \frac{2\pi v_p}{\omega} = \frac{v_p}{f}$$

$$\text{or, } \lambda f = v_p \dots\dots\dots(6.7)$$

Thus wavelength  $\lambda$  also represents the distance covered in one oscillation of the wave.

Similarly,  $E^-(z,t) = E_0^- \cos(\omega t + kz)$  represents a plane wave traveling in the -z direction.

The associated magnetic field can be found as follows:

From (6.4),

$$\begin{aligned}\vec{E}^+(z) &= E_0^+ e^{-jkz} \hat{a}_x \\ \vec{H} &= -\frac{1}{j\omega\mu} \nabla \times \vec{E} \\ &= -\frac{1}{j\omega\mu} \begin{vmatrix} \hat{a}_x & \hat{a}_y & \hat{a}_z \\ 0 & 0 & \partial \\ E_0^+ e^{-jkz} & 0 & 0 \end{vmatrix} \\ &= \frac{k}{\omega\mu} E_0^+ e^{-jkz} \hat{a}_y \\ &= \frac{E_0^+}{\eta} e^{-jkz} \hat{a}_y = H_0^+ e^{-jkz} \hat{a}_y \quad \dots\dots\dots(6.8)\end{aligned}$$

where  $\eta = \frac{\omega\mu}{k} = \frac{\omega\mu}{\omega\sqrt{\mu\epsilon}} = \sqrt{\frac{\mu}{\epsilon}}$  is the intrinsic impedance of the medium.

When the wave travels in free space

$$\eta_0 = \sqrt{\frac{\mu_0}{\epsilon_0}} \cong 120\pi = 377\Omega \quad \text{is the intrinsic impedance of the free space.}$$

In the time domain,

$$\vec{H}^+(z,t) = \hat{a}_y \frac{E_0^+}{\eta} \cos(\omega t - \beta z) \quad \dots\dots\dots(6.9)$$

Which represents the magnetic field of the wave traveling in the +z direction.

For the negative traveling wave,

$$\vec{H}^-(z,t) = -a_y \frac{E_0^+}{\eta} \cos(\omega t + \beta z) \dots\dots\dots(6.10)$$

For the plane waves described, both the E & H fields are perpendicular to the direction of propagation, and these waves are called TEM (transverse electromagnetic) waves.

The E & H field components of a TEM wave is shown in Fig 6.2.

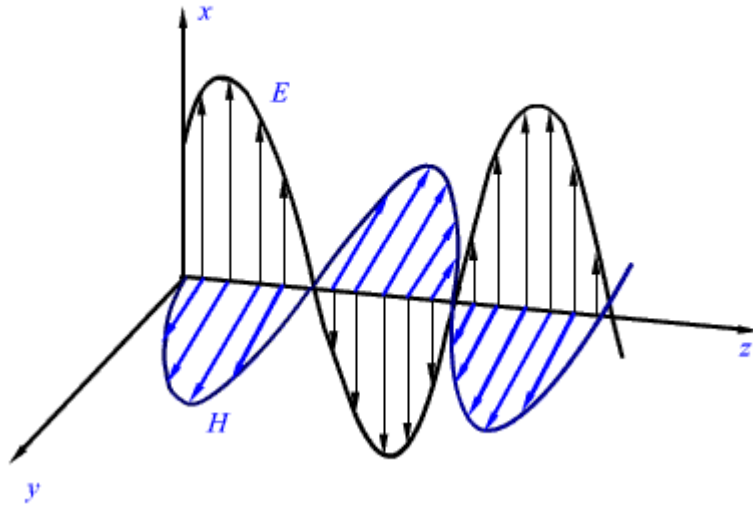

Figure 6.2 : E & H fields of a particular plane wave at time t.

**TEM Waves:**

So far we have considered a plane electromagnetic wave propagating in the z-direction. Let us now consider the propagation of a uniform plane wave in any arbitrary direction that doesn't necessarily coincides with an axis.

For a uniform plane wave propagating in z-direction

$$\vec{E}(z) = E_0 e^{-jkz}, \quad E_0 \text{ is a constant vector} \dots\dots\dots (6.11)$$

The more general form of the above equation is

$$\vec{E}(x,y,z) = \vec{E}_0 e^{-jk_x x - jk_y y - jk_z z} \dots\dots\dots (6.12)$$

This equation satisfies Helmholtz's equation  $\nabla^2 \vec{E} + k^2 \vec{E} = 0$  provided,

$$k_x^2 + k_y^2 + k_z^2 = k^2 = \omega^2 \mu \epsilon \dots\dots\dots (6.13)$$

We define wave number vector  $\vec{k} = \hat{a}_x k_x + \hat{a}_y k_y + \hat{a}_z k_z = k \hat{a}_n$  ..... (6.14)

And radius vector from the origin

$$\vec{r} = \hat{a}_x x + \hat{a}_y y + \hat{a}_z z \text{ ..... (6.15)}$$

Therefore we can write

$$\vec{E}(\vec{r}) = \vec{E}_0 e^{-j\vec{k}\vec{r}} = \vec{E}_0 e^{-jk\hat{a}_n\vec{r}} \text{ ..... (6.16)}$$

Here  $\hat{a}_n \cdot \vec{r} = \text{constant}$  is a plane of constant phase and uniform amplitude just in the case of  $\vec{E}(z) = \vec{E}_0 e^{-jkz}$ ,

$z = \text{constant}$  denotes a plane of constant phase and uniform amplitude.

If the region under consideration is charge free,

$$\begin{aligned} \nabla \cdot \vec{E} &= 0 \\ \therefore \nabla \cdot (\vec{E}_0 e^{-j\vec{k}\vec{r}}) &= 0 \end{aligned}$$

Using the vector identity  $\nabla \cdot (f\vec{A}) = \vec{A}\nabla f + f\nabla\cdot\vec{A}$  and noting that  $\vec{E}_0$  is constant we can write,

$$\begin{aligned} \vec{E}_0 \cdot \nabla (e^{-jk\hat{a}_n\vec{r}}) &= 0 \\ \text{or, } \vec{E}_0 \cdot \left[ \left( \frac{\partial}{\partial x} \hat{a}_x + \frac{\partial}{\partial y} \hat{a}_y + \frac{\partial}{\partial z} \hat{a}_z \right) e^{-j(k_x x + k_y y + k_z z)} \right] &= 0 \\ \text{or, } \vec{E}_0 \cdot \left( -jk \hat{a}_n e^{-jk\hat{a}_n\vec{r}} \right) &= 0 \end{aligned}$$

$$\vec{E}_0 \cdot \hat{a}_n = 0 \text{ .....(6.17)}$$

i.e.,  $\vec{E}_0$  is transverse to the direction of the propagation.

The corresponding magnetic field can be computed as follows:

$$\vec{H}(\vec{r}) = -\frac{1}{j\omega\mu} \nabla \times \vec{E}(\vec{r}) = -\frac{1}{j\omega\mu} \nabla \times (\vec{E}_0 e^{-j\vec{k}\cdot\vec{r}})$$

Using the vector identity,

$$\nabla \times (\psi \vec{A}) = \psi \nabla \times \vec{A} + \nabla \psi \times \vec{A}$$

Since  $\vec{E}_0$  is constant we can write,

$$\begin{aligned} \vec{H}(\vec{r}) &= -\frac{1}{j\omega\mu} \nabla e^{-j\vec{k}\cdot\vec{r}} \times \vec{E}_0 \\ &= -\frac{1}{j\omega\mu} \left[ -jk \hat{a}_n \times \vec{E}_0 e^{-jk \hat{a}_n \cdot \vec{r}} \right] \\ &= \frac{k}{\omega\mu} \hat{a}_n \times \vec{E}(\vec{r}) \end{aligned}$$

$$\vec{H}(\vec{r}) = \frac{1}{\eta} \hat{a}_n \times \vec{E}(\vec{r}) \quad \dots\dots\dots(6.18)$$

Where  $\eta$  is the intrinsic impedance of the medium. We observe that  $\vec{H}(\vec{r})$  is perpendicular to both  $\hat{a}_n$  and  $\vec{E}(\vec{r})$ . Thus the electromagnetic wave represented by  $\vec{E}(\vec{r})$  and  $\vec{H}(\vec{r})$  is a TEM wave.

Plane waves in a lossy medium :

In a lossy medium, the EM wave loses power as it propagates. Such a medium is conducting with conductivity  $\sigma$  and we can write:

$$\begin{aligned} \nabla \times \vec{H} &= \vec{J} + j\omega\epsilon\vec{E} = (\sigma + j\omega\epsilon)\vec{E} \\ &= j\omega \left( \epsilon + \frac{\sigma}{j\omega} \right) \vec{E} \\ &= j\omega\epsilon_c \vec{E} \quad \dots\dots\dots(6.19) \end{aligned}$$

Where  $\epsilon_c = \epsilon - j\frac{\sigma}{\omega} = \epsilon' - j\epsilon''$  is called the complex permittivity.

We have already discussed how an external electric field can polarize a dielectric and give rise to bound charges. When the external electric field is time varying, the polarization vector will vary with the same frequency as that of the applied field. As the frequency of the applied field increases, the inertia of the charge particles tend to prevent the particle displacement

keeping pace with the applied field changes. This results in frictional damping mechanism causing power loss.

In addition, if the material has an appreciable amount of free charges, there will be ohmic losses. It is customary to include the effect of damping and ohmic losses in the imaginary part of  $\epsilon_c$ . An equivalent conductivity  $\sigma = \omega \epsilon''$  represents all losses.

The ratio  $\frac{\epsilon''}{\epsilon'}$  is called loss tangent as this quantity is a measure of the power loss.

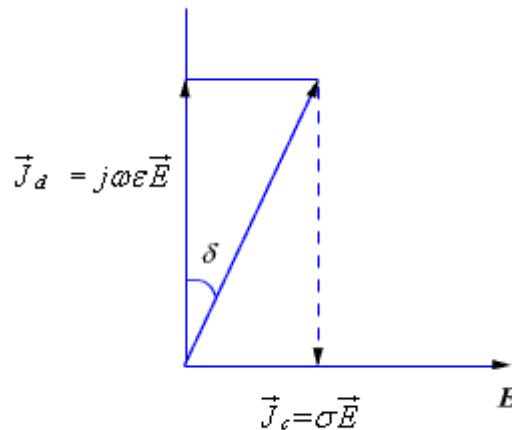

**Fig 6.3 : Calculation of Loss Tangent**

With reference to the Fig 6.3,

$$\tan \delta = \frac{|\vec{J}_c|}{|\vec{J}_d|} = \frac{\sigma}{\omega\epsilon} = \frac{\epsilon''}{\epsilon'} \dots\dots\dots (6.20)$$

where  $\vec{J}_c$  is the conduction current density and  $\vec{J}_d$  is displacement current density. The loss tangent gives a measure of how much lossy is the medium under consideration. For a good dielectric medium ( $\sigma \ll \omega\epsilon$ ),  $\tan \delta$  is very small and the medium is a good conductor if ( $\sigma \gg \omega\epsilon$ ). A material may be a good conductor at low frequencies but behave as lossy dielectric at higher frequencies.

For a source free lossy medium we can write

$$\left. \begin{aligned} \nabla \times \vec{H} &= (\sigma + j\omega\epsilon)\vec{E} & \nabla \cdot \vec{H} &= 0 \\ \nabla \times \vec{E} &= -j\omega\mu\vec{H} & \nabla \cdot \vec{E} &= 0 \end{aligned} \right\} \dots\dots\dots (6.21)$$

$$\begin{aligned}\nabla \times \nabla \times \vec{E} &= \nabla(\nabla \cdot \vec{E}) - \nabla^2 \vec{E} = -j\omega\mu\nabla \times \vec{H} = -j\omega\mu(\sigma + j\omega\varepsilon)\vec{E} \\ \text{or, } \nabla^2 \vec{E} - \gamma^2 \vec{E} &= 0\end{aligned}\quad \dots\dots\dots (6.22)$$

Where  $\gamma^2 = j\omega\mu(\sigma + j\omega\varepsilon)$

Proceeding in the same manner we can write,

$$\nabla^2 \vec{H} - \gamma^2 \vec{H} = 0$$

$$\gamma = \alpha + i\beta = \sqrt{j\omega\mu(\sigma + j\omega\varepsilon)} = j\omega\sqrt{\mu\varepsilon} \left(1 + \frac{\sigma}{j\omega\varepsilon}\right)^{1/2}$$

is called the propagation constant.

The real and imaginary parts  $\alpha$  and  $\beta$  of the propagation constant  $\gamma$  can be computed as follows:

$$\begin{aligned}\gamma^2 &= (\alpha + i\beta)^2 = j\omega\mu(\sigma + j\omega\varepsilon) \\ \text{or, } \alpha^2 - \beta^2 &= -\omega^2\mu\varepsilon\end{aligned}$$

$$\text{And } \alpha\beta = \frac{\omega\mu\sigma}{2}$$

$$\therefore \alpha^2 - \left(\frac{\omega\mu\sigma}{2\alpha}\right)^2 = -\omega^2\mu\varepsilon$$

$$\text{or, } 4\alpha^4 + 4\alpha^2\omega^2\mu\varepsilon = \omega^2\mu^2\sigma^2$$

$$\text{or, } 4\alpha^4 + 4\alpha^2\omega^2\mu\varepsilon + \omega^4\mu^2\varepsilon^2 = \omega^2\mu^2\sigma^2 + \omega^4\mu^2\varepsilon^2$$

$$\text{or, } (2\alpha^2 + \omega^2\mu\varepsilon)^2 = \omega^4\mu^2\varepsilon^2 \left(1 + \frac{\sigma^2}{\omega^2\varepsilon^2}\right)$$

$$\text{or, } \alpha = \omega \sqrt{\frac{\mu\varepsilon}{2} \left[ \sqrt{1 + \left(\frac{\sigma}{\omega\varepsilon}\right)^2} - 1 \right]}\quad \dots\dots\dots (6.23a)$$

$$\beta = \omega \sqrt{\frac{\mu\epsilon}{2} \left[ \sqrt{1 + \left(\frac{\sigma}{\omega\epsilon}\right)^2} + 1 \right]}$$

Similarly ..... (6.23b)

Let us now consider a plane wave that has only x -component of electric field and propagate along z .

$$\therefore \vec{E}_x(z) = (E_0^+ e^{-\gamma z} + E_0^- e^{-\gamma z}) \hat{a}_x \quad \text{..... (6.24)}$$

Considering only the forward traveling wave

$$\begin{aligned} \vec{E}(z,t) &= \text{Re} \left( E_0^+ e^{-\gamma z} e^{j\omega t} \right) \hat{a}_x \\ &= E_0^+ e^{-\alpha z} \cos(\omega t - \beta z) \hat{a}_x \quad \text{..... (6.25)} \end{aligned}$$

Similarly, from  $\vec{H} = -\frac{1}{j\omega\mu} \nabla \times \vec{E}$  , we can find

$$\vec{H}(z,t) = \frac{E_0}{\eta} e^{-\alpha z} \cos(\omega t - \beta z) \hat{a}_y \quad \text{..... (6.26)}$$

Where  $\eta = \sqrt{\frac{j\omega\mu}{\sigma + j\omega\epsilon}} = |\eta| e^{j\theta_\eta}$

$$\therefore \vec{H} = \frac{E_0}{|\eta|} e^{-\alpha z} \cos(\omega t - \beta z - \theta_\eta) \hat{a}_y \quad \text{..... (6.27)}$$

From (6.25) and (6.26) we find that as the wave propagates along z, it decreases in amplitude by a factor  $e^{-\alpha z}$ . Therefore  $\alpha$  is known as attenuation constant. Further  $\vec{E}$  and  $\vec{H}$  are out of phase by an angle  $\theta_\eta$ .

For low loss dielectric,  $\frac{\sigma}{\omega\epsilon} \ll 1$ , i.e.,  $\epsilon'' \ll \epsilon'$ .

Using the above condition approximate expression for  $\alpha$  and  $\beta$  can be obtained as follows:

$$\gamma = \alpha + j\beta = j\omega\sqrt{\mu\epsilon'} \left[ 1 - j\frac{\epsilon''}{\epsilon'} \right]^{1/2}$$



$$\cong j\omega\sqrt{\mu\varepsilon'} \left[ 1 - j\frac{1}{2}\frac{\varepsilon''}{\varepsilon'} + \frac{1}{8}\left(\frac{\varepsilon''}{\varepsilon'}\right)^2 \right]$$

$$\left. \begin{aligned} \alpha &= \frac{\omega\varepsilon''}{2} \sqrt{\frac{\mu}{\varepsilon'}} \\ \beta &= \omega\sqrt{\mu\varepsilon'} \left[ 1 + \frac{1}{8}\left(\frac{\varepsilon''}{\varepsilon'}\right)^2 \right] \end{aligned} \right\} \dots\dots\dots (6.28)$$

$$\eta = \sqrt{\frac{\mu}{\varepsilon'}} \left( 1 - j\frac{\varepsilon''}{\varepsilon'} \right)^{-1/2}$$

$$= \sqrt{\frac{\mu}{\varepsilon'}} \left( 1 + j\frac{\varepsilon''}{2\varepsilon'} \right) \dots\dots\dots (6.29)$$

& phase velocity

$$v_p = \frac{\omega}{\beta} \cong \frac{1}{\sqrt{\mu\varepsilon'}} \left[ 1 - \frac{1}{8}\left(\frac{\varepsilon''}{\varepsilon'}\right)^2 \right] \dots\dots\dots (6.30)$$

For good conductors  $\frac{\sigma}{\omega\varepsilon} \gg 1$

$$\gamma = j\omega\sqrt{\mu\varepsilon} \left( 1 + \frac{\sigma}{j\omega\varepsilon} \right) \cong j\omega\sqrt{\mu\varepsilon} \sqrt{\frac{\sigma}{j\omega\varepsilon}}$$

$$= \frac{1+j}{\sqrt{2}} \sqrt{\omega\mu\sigma} \dots\dots\dots (6.31)$$

We have used the relation

$$\sqrt{j} = (e^{j\pi/2})^{1/2} = e^{j\pi/4} = \frac{1}{\sqrt{2}}(1+j)$$

From (6.31) we can write

$$\alpha + i\beta = \sqrt{\pi f \mu \sigma} + j\sqrt{\pi f \mu \sigma}$$

$$\therefore \alpha = \beta = \sqrt{\pi f \mu \sigma} \dots\dots\dots (6.32)$$

$$\begin{aligned}
 \eta &= \sqrt{\frac{j\omega\mu}{j\omega\varepsilon\left(1+\frac{\sigma}{j\omega\varepsilon}\right)}} \\
 &\cong \sqrt{\frac{\mu j\omega\varepsilon}{\varepsilon\sigma}} = \sqrt{\frac{j\omega\mu}{\sigma}} \\
 &= (1+j)\sqrt{\frac{\pi f\mu}{\sigma}} \\
 &= (1+j)\frac{\alpha}{\sigma} \dots\dots\dots (6.33)
 \end{aligned}$$

And phase velocity

$$v_p = \frac{\omega}{\beta} \cong \sqrt{\frac{2\omega}{\mu\sigma}} \dots\dots\dots (6.34)$$

### Poynting Vector and Power Flow in Electromagnetic Fields:

Electromagnetic waves can transport energy from one point to another point. The electric and magnetic field intensities associated with a travelling electromagnetic wave can be related to the rate of such energy transfer.

Let us consider Maxwell's Curl Equations:

$$\begin{aligned}
 \nabla \times \vec{E} &= -\frac{\partial \vec{B}}{\partial t} \\
 \nabla \times \vec{H} &= \vec{J} + \frac{\partial \vec{D}}{\partial t}
 \end{aligned}$$

Using vector identity

$$\nabla \cdot (\vec{E} \times \vec{H}) = \vec{H} \cdot \nabla \times \vec{E} - \vec{E} \cdot \nabla \times \vec{H}$$

the above curl equations we can write

$$\nabla \cdot (\vec{E} \times \vec{H}) = -\vec{H} \cdot \frac{\partial \vec{B}}{\partial t} - \vec{E} \cdot \left( \vec{J} + \frac{\partial \vec{D}}{\partial t} \right)$$

$$\text{or, } \nabla \cdot (\vec{E} \times \vec{H}) = -\vec{H} \cdot \frac{\partial \vec{B}}{\partial t} - \vec{E} \cdot \vec{J} - \vec{E} \cdot \frac{\partial \vec{D}}{\partial t} \dots \dots \dots (6.35)$$

In simple medium where  $\epsilon$ ,  $\mu$  and  $\sigma$  are constant, we can write

$$\begin{aligned} \vec{H} \cdot \frac{\partial \vec{B}}{\partial t} &= \frac{\partial}{\partial t} \left( \frac{1}{2} \mu H^2 \right) \\ \vec{E} \cdot \frac{\partial \vec{D}}{\partial t} &= \frac{\partial}{\partial t} \left( \frac{1}{2} \mu E^2 \right) \quad \text{and} \quad \vec{E} \cdot \vec{J} = \sigma E^2 \\ \therefore \nabla \cdot (\vec{E} \times \vec{H}) &= -\frac{\partial}{\partial t} \left( \frac{1}{2} \epsilon E^2 + \frac{1}{2} \mu H^2 \right) - \sigma E^2 \end{aligned}$$

Applying Divergence theorem we can write,

$$\oint_S (\vec{E} \times \vec{H}) \cdot d\vec{S} = -\frac{\partial}{\partial t} \int_V \left( \frac{1}{2} \epsilon E^2 + \frac{1}{2} \mu H^2 \right) dV - \int_V \sigma E^2 dV \dots \dots \dots (6.36)$$

The term  $\frac{\partial}{\partial t} \int_V \left( \frac{1}{2} \epsilon E^2 + \frac{1}{2} \mu H^2 \right) dV$  represents the rate of change of energy stored in the electric and magnetic fields and the term  $\int_V \sigma E^2 dV$  represents the power dissipation within the volume. Hence right hand side of the equation (6.36) represents the total decrease in power within the volume under consideration.

The left hand side of equation (6.36) can be written as  $\oint_S (\vec{E} \times \vec{H}) \cdot d\vec{S} = \oint_S \vec{P} \cdot d\vec{S}$  where  $\vec{P} = \vec{E} \times \vec{H}$  (W/m<sup>2</sup>) is called the Poynting vector and it represents the power density vector associated with the electromagnetic field. The integration of the Poynting vector over any closed surface gives the net power flowing out of the surface. Equation (6.36) is referred to as Poynting theorem and it states that the net power flowing out of a given volume is equal to the time rate of decrease in the energy stored within the volume minus the conduction losses.

### Poynting vector for the time harmonic case:

For time harmonic case, the time variation is of the form  $e^{j\omega t}$ , and we have seen that instantaneous value of a quantity is the real part of the product of a phasor quantity and  $e^{j\omega t}$  when  $\cos \omega t$  is used as reference. For example, if we consider the phasor

$$\vec{E}(z) = \hat{a}_x E_x(z) = \hat{a}_x E_0 e^{-j\beta z}$$

then we can write the instantaneous field as

$$\vec{E}(z, t) = \text{Re} \left[ \vec{E}(z) e^{j\omega t} \right] = E_0 \cos(\omega t - \beta z) \hat{a}_x \dots\dots\dots(6.37)$$

when  $E_0$  is real.

Let us consider two instantaneous quantities A and B such that

$$A = \text{Re} \left( A e^{j\omega t} \right) = |A| \cos(\omega t + \alpha)$$

$$B = \text{Re} \left( B e^{j\omega t} \right) = |B| \cos(\omega t + \beta)$$

where A and B are the phasor quantities.

$$\text{i.e., } A = |A| e^{j\alpha}$$

$$B = |B| e^{j\beta}$$

Therefore,

$$\begin{aligned} AB &= |A| \cos(\omega t + \alpha) |B| \cos(\omega t + \beta) \\ &= \frac{1}{2} |A| |B| \left[ \cos(\alpha - \beta) + \cos(2\omega t + \alpha + \beta) \right] \dots\dots\dots(6.39) \end{aligned}$$

Since A and B are periodic with period  $T = \frac{2\pi}{\omega}$ , the time average value of the product form AB, denoted by  $\overline{AB}$  can be written as

$$\overline{AB} = \frac{1}{T} \int_0^T AB dt$$

$$\overline{AB} = \frac{1}{2} |A| |B| \cos(\alpha - \beta) \dots\dots\dots(6.40)$$

Further, considering the phasor quantities A and B, we find that

$$AB^* = |A|e^{j\alpha} |B|e^{-j\beta} = |A||B|e^{j(\alpha-\beta)}$$

and  $\text{Re}(AB^*) = |A||B|\cos(\alpha - \beta)$ , where \* denotes complex conjugate.

$$\therefore \overline{AB} = \frac{1}{2} \text{Re}(AB^*) \dots\dots\dots(6.41)$$

The Poynting vector  $\vec{P} = \vec{E} \times \vec{H}$  can be expressed as

$$\vec{P} = \hat{a}_x (E_y H_z - E_z H_y) + \hat{a}_y (E_z H_x - E_x H_z) + \hat{a}_z (E_x H_y - E_y H_x) \dots\dots\dots(6.42)$$

If we consider a plane electromagnetic wave propagating in +z direction and has only  $E_x$  component, from (6.42) we can write:

$$\vec{P}_z = E_x(z,t) H_y(z,t) \hat{a}_z$$

Using (6.41)

$$\vec{P}_{zav} = \frac{1}{2} \text{Re} \left( E_x(z) H_y^*(z) \hat{a}_z \right)$$

$$\vec{P}_{zav} = \frac{1}{2} \text{Re} (E_x(z) \times H_y(z)) \dots\dots\dots(6.43)$$

where  $\vec{E}(z) = E_x(z) \hat{a}_x$  and  $\vec{H}(z) = H_y(z) \hat{a}_y$ , for the plane wave under consideration.

For a general case, we can write

$$\vec{P}_w = \frac{1}{2} \text{Re} (\vec{E} \times \vec{H}^*) \dots\dots\dots(6.44)$$

We can define a complex Poynting vector

$$\vec{S} = \frac{1}{2} \vec{E} \times \vec{H}^*$$

and time average of the instantaneous Poynting vector is given by  $\vec{P}_w = \text{Re}(\vec{S})$ .

**Polarisation of plane wave:**

The polarisation of a plane wave can be defined as the orientation of the electric field vector as a function of time at a fixed point in space. For an electromagnetic wave, the specification of the orientation of the electric field is sufficient as the magnetic field components are related to electric field vector by the Maxwell's equations.

Let us consider a plane wave travelling in the +z direction. The wave has both  $E_x$  and  $E_y$  components.

$$\vec{E} = \left( \hat{a}_x E_{ox} + \hat{a}_y E_{oy} \right) e^{-j\beta z} \dots\dots\dots(6.45)$$

The corresponding magnetic fields are given by,

$$\begin{aligned} \vec{H} &= \frac{1}{\eta} \hat{a}_z \times \vec{E} \\ &= \frac{1}{\eta} \hat{a}_z \times \left( \hat{a}_x E_{ox} + \hat{a}_y E_{oy} \right) e^{-j\beta z} \\ &= \frac{1}{\eta} \left( -E_{oy} \hat{a}_x + E_{ox} \hat{a}_y \right) e^{-j\beta z} \end{aligned}$$

Depending upon the values of  $E_{ox}$  and  $E_{oy}$  we can have several possibilities:

1. If  $E_{oy} = 0$ , then the wave is linearly polarised in the  $x$ -direction.
2. If  $E_{ox} = 0$ , then the wave is linearly polarised in the  $y$ -direction.
3. If  $E_{ox}$  and  $E_{oy}$  are both real (or complex with equal phase), once again we get a linearly

polarised wave with the axis of polarisation inclined at an angle  $\tan^{-1} \frac{E_{oy}}{E_{ox}}$ , with respect to the  $x$ -axis. This is shown in fig 6.4.

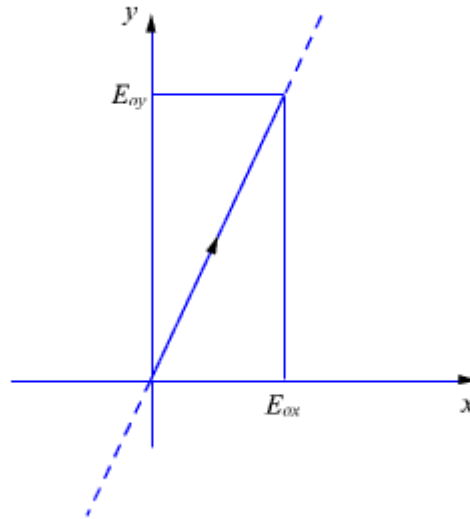

Fig 6.4 : Linear Polarisation

4. If  $E_{ox}$  and  $E_{oy}$  are complex with different phase angles,  $\vec{E}$  will not point to a single spatial direction. This is explained as follows:

$$\text{Let } E_{ox} = |E_{ox}| e^{j\alpha}$$

$$E_{oy} = |E_{oy}| e^{j\beta}$$

Then,

$$E_x(z, t) = \text{Re} \left[ |E_{ox}| e^{j\alpha} e^{-j\beta z} e^{j\omega t} \right] = |E_{ox}| \cos(\omega t - \beta z + \alpha)$$

$$\text{and } E_y(z, t) = \text{Re} \left[ |E_{oy}| e^{j\beta} e^{-j\beta z} e^{j\omega t} \right] = |E_{oy}| \cos(\omega t - \beta z + b) \dots\dots\dots(6.46)$$

To keep the things simple, let us consider  $\alpha = 0$  and  $b = \frac{\pi}{2}$ . Further, let us study the nature of the electric field on the  $z = 0$  plain.

From equation (6.46) we find that,

$$E_x(o, t) = |E_{ox}| \cos \omega t$$

$$E_y(o, t) = |E_{oy}| \cos \left( \omega t + \frac{\pi}{2} \right) = |E_{oy}| (-\sin \omega t)$$

$$\therefore \left( \frac{E_x(o,t)}{|E_{ox}|} \right)^2 + \left( \frac{E_y(o,t)}{|E_{oy}|} \right)^2 = \cos^2 \omega t + \sin^2 \omega t = 1 \quad \dots\dots\dots(6.47)$$

and the electric field vector at  $z = 0$  can be written as

$$\vec{E}(o,t) = |E_{ox}| \cos(\omega t) \hat{a}_x - |E_{oy}| \sin(\omega t) \hat{a}_y \quad \dots\dots\dots(6.48)$$

Assuming  $|E_{ox}| > |E_{oy}|$ , the plot of  $\vec{E}(o,t)$  for various values of  $t$  is shown in figure 6.5.

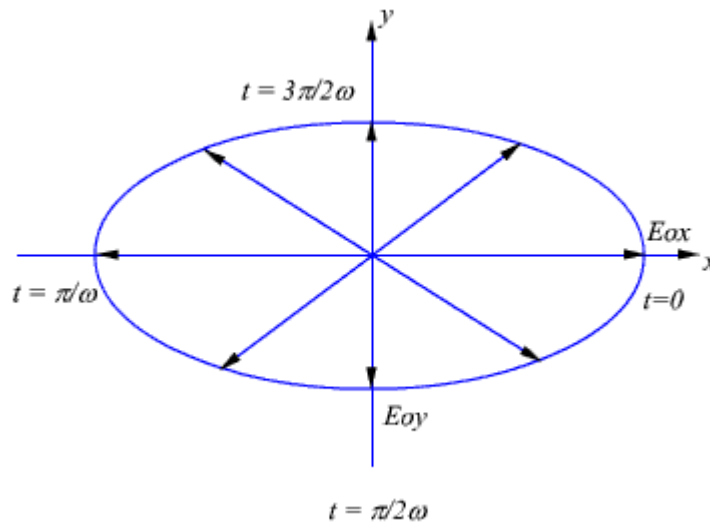

**Figure 6.5 : Plot of  $E(o,t)$**

From equation (6.47) and figure (6.5) we observe that the tip of the arrow representing electric field vector traces an ellipse and the field is said to be elliptically polarised.



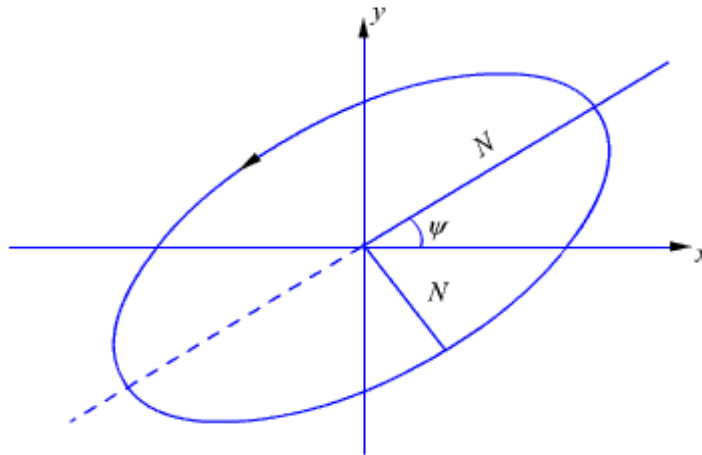
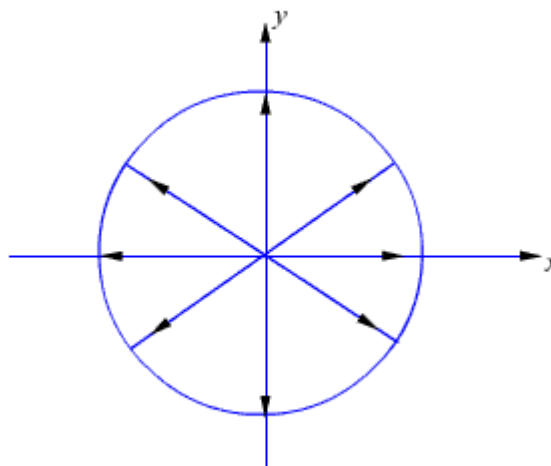

**Figure 6.6: Polarisation ellipse**

The polarisation ellipse shown in figure 6.6 is defined by its axial ratio ( $M/N$ , the ratio of semimajor to semiminor axis), tilt angle  $\psi$  (orientation with respect to x-axis) and sense of rotation (i.e., CW or CCW).

Linear polarisation can be treated as a special case of elliptical polarisation, for which the axial ratio is infinite.

In our example, if  $|E_{\sigma x}| = |E_{\sigma y}|$ , from equation (6.47), the tip of the arrow representing electric field vector traces out a circle. Such a case is referred to as Circular Polarisation. For circular polarisation the axial ratio is unity.



**Figure 6.7: Circular Polarisation (RHCP)**

Further, the circular polarisation is said to be right handed circular polarisation (RHCP) if the electric field vector rotates in the direction of the fingers of the right hand when the thumb points in the direction of propagation (same as CCW). If the electric field vector rotates in the opposite direction, the polarisation is said to be left hand circular polarisation (LHCP) (same as CW).

In AM radio broadcast, the radiated electromagnetic wave is linearly polarised with the  $\vec{E}$  field vertical to the ground (vertical polarisation) whereas TV signals are horizontally polarised waves. FM broadcast is usually carried out using circularly polarised waves.

In radio communication, different information signals can be transmitted at the same frequency at orthogonal polarisation (one signal as vertically polarised other horizontally polarised or one as RHCP while the other as LHCP) to increase capacity. Otherwise, same signal can be transmitted at orthogonal polarisation to obtain diversity gain to improve reliability of transmission.

### Behaviour of Plane waves at the interface of two media:

We have considered the propagation of uniform plane waves in an unbounded homogeneous medium. In practice, the wave will propagate in bounded regions where several values of  $\epsilon, \mu, \sigma$  will be present. When a plane wave travelling in one medium meets a different medium, it is partly reflected and partly transmitted. In this section, we consider wave reflection and transmission at a planar boundary between two media.

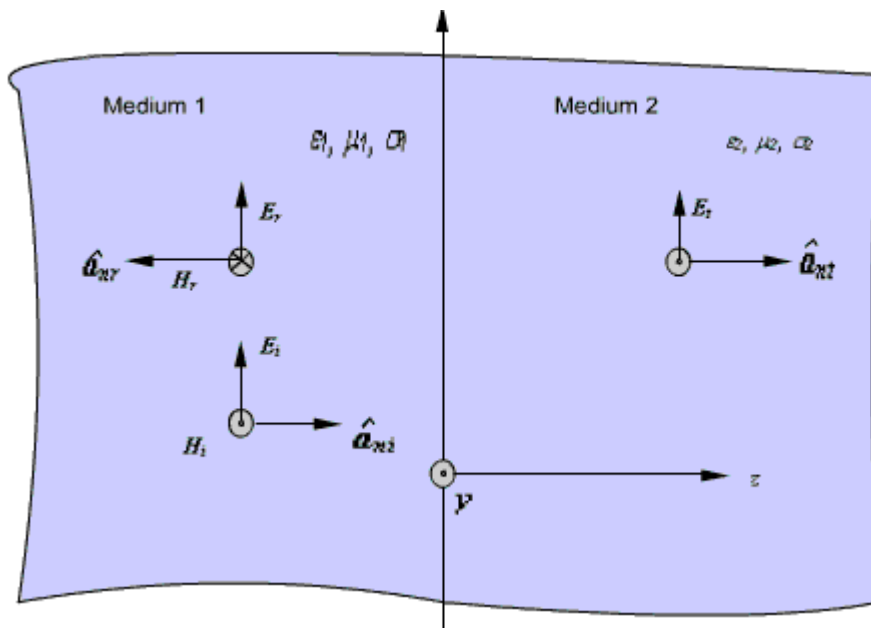

**Fig 6.8 : Normal Incidence at a plane boundary**

**Case1:** Let  $z = 0$  plane represent the interface between two media. Medium 1 is characterised by  $(\epsilon_1, \mu_1, \sigma_1)$  and medium 2 is characterized by  $(\epsilon_2, \mu_2, \sigma_2)$ .

Let the subscripts 'i' denotes incident, 'r' denotes reflected and 't' denotes transmitted field components respectively.

The incident wave is assumed to be a plane wave polarized along x and travelling in medium 1 along  $\hat{a}_z$  direction. From equation (6.24) we can write

$$\vec{E}_i(z) = E_{i0} e^{-\gamma_1 z} \hat{a}_x \dots\dots\dots(6.49.a)$$

$$\vec{H}_i(z) = \frac{1}{\eta_1} \hat{a}_z \times E_{i0} e^{-\gamma_1 z} \hat{a}_x = \frac{E_{i0}}{\eta_1} e^{-\gamma_1 z} \hat{a}_y \dots\dots\dots(6.49.b)$$

where  $\gamma_1 = \sqrt{j\omega\mu_1(\sigma_1 + j\omega\epsilon_1)}$  and  $\eta_1 = \sqrt{\frac{j\omega\mu_1}{\sigma_1 + j\omega\epsilon_1}}$ .

Because of the presence of the second medium at  $z=0$ , the incident wave will undergo partial reflection and partial transmission.

The reflected wave will travel along  $\hat{a}_z$  in medium 1.

The reflected field components are:

$$\vec{E}_r = E_{r0} e^{\gamma_1 z} \hat{a}_x \dots\dots\dots(6.50a)$$

$$\vec{H}_r = \frac{1}{\eta_1} \left( -\hat{a}_z \right) \times E_{r0} e^{\gamma_1 z} \hat{a}_x = -\frac{E_{r0}}{\eta_1} e^{\gamma_1 z} \hat{a}_y \dots\dots\dots(6.50b)$$

The transmitted wave will travel in medium 2 along  $\hat{a}_z$  for which the field components are

$$\vec{E}_t = E_{t0} e^{-\gamma_2 z} \hat{a}_x \dots\dots\dots(6.51a)$$

$$\vec{H}_t = \frac{E_{t0}}{\eta_2} e^{-\gamma_2 z} \hat{a}_y \dots\dots\dots(6.51b)$$

where  $\gamma_2 = \sqrt{j\omega\mu_2(\sigma_2 + j\omega\epsilon_2)}$  and  $\eta_2 = \sqrt{\frac{j\omega\mu_2}{\sigma_2 + j\omega\epsilon_2}}$

In medium 1,

$$\vec{E}_1 = \vec{E}_i + \vec{E}_r \text{ and } \vec{H}_1 = \vec{H}_i + \vec{H}_r$$

and in medium 2,

$$\vec{E}_2 = \vec{E}_t \text{ and } \vec{H}_2 = \vec{H}_t$$

Applying boundary conditions at the interface  $z = 0$ , i.e., continuity of tangential field components and noting that incident, reflected and transmitted field components are tangential at the boundary, we can write

$$\vec{E}_i(0) + \vec{E}_r(0) = \vec{E}_t(0)$$

$$\& \vec{H}_i(0) + \vec{H}_r(0) = \vec{H}_t(0)$$

From equation 6.49 to 6.51 we get,

$$E_{i0} + E_{r0} = E_{t0} \dots\dots\dots(6.52a)$$

$$\frac{E_{i0}}{\eta_1} - \frac{E_{r0}}{\eta_1} = \frac{E_{t0}}{\eta_2} \dots\dots\dots(6.52b)$$

Eliminating  $E_{t0}$ ,

$$\frac{E_{i0}}{\eta_1} - \frac{E_{r0}}{\eta_1} = \frac{1}{\eta_2} (E_{i0} + E_{r0})$$

$$\text{or, } E_{i0} \left( \frac{1}{\eta_1} - \frac{1}{\eta_2} \right) = E_{r0} \left( \frac{1}{\eta_1} + \frac{1}{\eta_2} \right)$$

$$\text{or, } E_{r0} = \tau E_{i0}$$

$$\tau = \frac{\eta_2 - \eta_1}{\eta_2 + \eta_1} \dots\dots\dots(6.53)$$

is called the reflection coefficient.

From equation (6.52), we can write

$$2E_{i0} = E_{r0} \left[ 1 + \frac{\eta_1}{\eta_2} \right]$$

$$\text{or, } E_{r0} = \frac{2\eta_2}{\eta_1 + \eta_2} E_{i0} = T E_{i0}$$

$$T = \frac{2\eta_2}{\eta_1 + \eta_2} \dots\dots\dots(6.54)$$

is called the transmission coefficient.

We observe that,

$$T = \frac{2\eta_2}{\eta_1 + \eta_2} = \frac{\eta_2 - \eta_1 + \eta_1 + \eta_2}{\eta_1 + \eta_2} = 1 + \tau \dots\dots\dots(6.55)$$

The following may be noted

(i) both  $\tau$  and T are dimensionless and may be complex

(ii)  $0 \leq |\tau| \leq 1$

Let us now consider specific cases:

### Case I: Normal incidence on a plane conducting boundary

The medium 1 is perfect dielectric ( $\sigma_1 = 0$ ) and medium 2 is perfectly conducting ( $\sigma_2 = \infty$ ).

$$\therefore \eta_1 = \sqrt{\frac{\mu_1}{\epsilon_1}}$$

$$\eta_2 = 0$$

$$\begin{aligned} \gamma_1 &= \sqrt{(j\omega\mu_1)(j\omega\epsilon_1)} \\ &= j\omega\sqrt{\mu_1\epsilon_1} = j\beta \end{aligned}$$

From (6.53) and (6.54)

$$\tau = -1$$

$$\text{and } T = 0$$

Hence the wave is not transmitted to medium 2, it gets reflected entirely from the interface to the medium 1.

$$\therefore \vec{E}_1(z) = E_{i0} e^{-j\beta_1 z} \hat{a}_x - E_{i0} e^{j\beta_1 z} \hat{a}_x = -2jE_{i0} \sin \beta_1 z \hat{a}_x$$

$$\therefore \vec{E}_1(z, t) = \text{Re} \left[ -2jE_{i0} \sin \beta_1 z e^{j\omega t} \right] \hat{a}_x = 2E_{i0} \sin \beta_1 z \sin \omega t \hat{a}_x \dots\dots\dots(6.56)$$

Proceeding in the same manner for the magnetic field in region 1, we can show that,

$$\vec{H}_1(z, t) = \hat{a}_y \frac{2E_{i0}}{\eta_1} \cos \beta_1 z \cos \omega t \dots\dots\dots(6.57)$$

The wave in medium 1 thus becomes a **standing wave** due to the super position of a forward travelling wave and a backward travelling wave. For a given 't', both  $\vec{E}_1$  and  $\vec{H}_1$  vary sinusoidally with distance measured from z = 0. This is shown in figure 6.9.

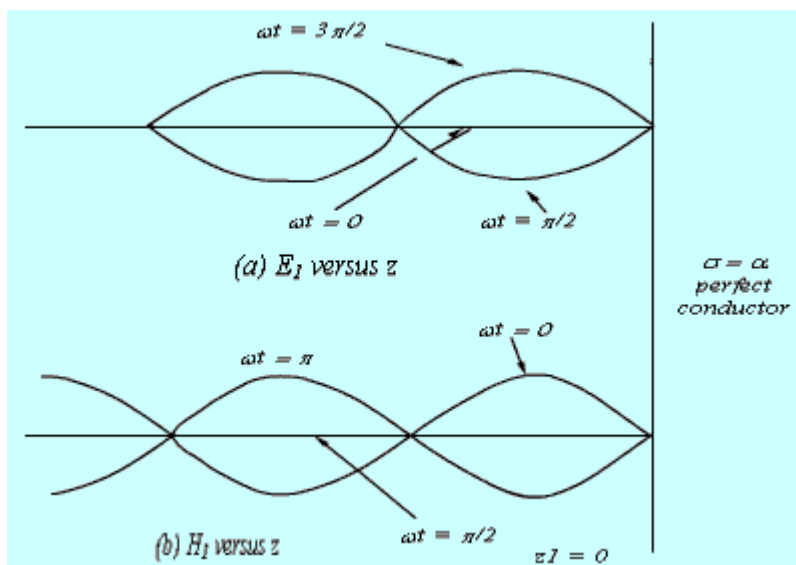

**Figure 6.9: Generation of standing wave**

Zeroes of  $E_1(z, t)$  and Maxima of  $H_1(z, t)$ .

Maxima of  $E_1(z, t)$  and zeroes of  $H_1(z, t)$ .

$$\left. \begin{array}{l} \text{occur at } \beta_1 z = -n\pi \quad \text{or } z = -n \frac{\lambda}{2} \\ \text{occur at } \beta_1 z = -(2n+1) \frac{\pi}{2} \quad \text{or } z = -(2n+1) \frac{\lambda}{4}, \quad n = 0, 1, 2, \dots \end{array} \right\}$$

$$\left. \begin{array}{l} \\ \\ \\ \\ \\ \end{array} \right\} \dots\dots\dots(6.58)$$

### Case2: Normal incidence on a plane dielectric boundary

If the medium 2 is not a perfect conductor (i.e.  $\sigma_2 \neq \infty$ ) partial reflection will result. There will be a reflected wave in the medium 1 and a transmitted wave in the medium 2. Because of the reflected wave, standing wave is formed in medium 1.

From equation (6.49(a)) and equation (6.53) we can write

$$\vec{E}_1 = E_{i0} (e^{-\gamma_1 z} + \Gamma e^{\gamma_1 z}) \hat{a}_x \dots\dots\dots(6.59)$$

Let us consider the scenario when both the media are dissipation less i.e. perfect dielectrics ( $\sigma_1 = 0, \sigma_2 = 0$ )

$$\begin{array}{ll} \gamma_1 = j\omega\sqrt{\mu_1\epsilon_1} = j\beta_1 & \eta_1 = \sqrt{\frac{\mu_1}{\epsilon_1}} \\ \gamma_2 = j\omega\sqrt{\mu_2\epsilon_2} = j\beta_2 & \eta_2 = \sqrt{\frac{\mu_2}{\epsilon_2}} \end{array} \dots\dots\dots(6.60)$$

In this case both  $\eta_1$  and  $\eta_2$  become real numbers.

$$\begin{aligned} \vec{E}_1 &= \hat{a}_x E_{i0} (e^{-j\beta_1 z} + \Gamma e^{j\beta_1 z}) \\ &= \hat{a}_x E_{i0} \left( (1 + \Gamma) e^{-j\beta_1 z} + \Gamma (e^{j\beta_1 z} - e^{-j\beta_1 z}) \right) \\ &= \hat{a}_x E_{i0} \left( T e^{-j\beta_1 z} + \Gamma (2j \sin \beta_1 z) \right) \end{aligned} \dots\dots\dots(6.61)$$

From (6.61), we can see that, in medium 1 we have a traveling wave component with amplitude  $TE_{io}$  and a standing wave component with amplitude  $2JE_{io}$ .

The location of the maximum and the minimum of the electric and magnetic field components in the medium 1 from the interface can be found as follows.

The electric field in medium 1 can be written as

$$\vec{E}_1 = \hat{a}_x E_{io} e^{-j\beta_1 z} (1 + \Gamma e^{j2\beta_1 z}) \dots\dots\dots(6.62)$$

If  $\eta_2 > \eta_1$  i.e.  $\Gamma > 0$

The maximum value of the electric field is

$$\left| \vec{E}_1 \right|_{\max} = E_{io} (1 + \Gamma) \dots\dots\dots(6.63)$$

and this occurs when

$$2\beta_1 z_{\max} = -2n\pi$$

$$\text{or } z_{\max} = -\frac{n\pi}{\beta_1} = -\frac{n\pi}{2\pi/\lambda_1} = -\frac{n}{2} \lambda_1, \quad n = 0, 1, 2, 3, \dots\dots\dots(6.64)$$

The minimum value of  $\left| \vec{E}_1 \right|$  is

$$\left| \vec{E}_1 \right|_{\min} = E_{io} (1 - \Gamma) \dots\dots\dots(6.65)$$

And this occurs when

$$2\beta_1 z_{\min} = -(2n + 1)\pi$$

$$\text{or } z_{\min} = -\frac{(2n + 1)\lambda_1}{4}, \quad n = 0, 1, 2, 3, \dots\dots\dots(6.66)$$

For  $\eta_2 < \eta_1$  i.e.  $\Gamma < 0$

The maximum value of  $\left| \vec{E}_1 \right|$  is  $E_{io} (1 - \Gamma)$  which occurs at the  $z_{\min}$  locations and the minimum value of  $\left| \vec{E}_1 \right|$  is  $E_{io} (1 + \Gamma)$  which occurs at  $z_{\max}$  locations as given by the equations (6.64) and (6.66).



From our discussions so far we observe that  $\frac{|E|_{\max}}{|E|_{\min}}$  can be written as

$$S = \frac{|E|_{\max}}{|E|_{\min}} = \frac{1 + |\Gamma|}{1 - |\Gamma|} \dots\dots\dots(6.67)$$

The quantity  $S$  is called as the standing wave ratio.

As  $0 \leq |\Gamma| \leq 1$  the range of  $S$  is given by  $1 \leq S \leq \infty$

From (6.62), we can write the expression for the magnetic field in medium 1 as

$$\vec{H}_1 = \hat{a}_y \frac{E_0}{\eta_1} e^{-j\beta_1 z} (1 - \Gamma e^{j2\beta_1 z}) \dots\dots\dots(6.68)$$

From (6.68) we find that  $|\vec{H}_1|$  will be maximum at locations where  $|\vec{E}_1|$  is minimum and vice versa.

In medium 2, the transmitted wave propagates in the + z direction.

### Oblique Incidence of EM wave at an interface

So far we have discuss the case of normal incidence where electromagnetic wave traveling in a lossless medium impinges normally at the interface of a second medium. In this section we shall consider the case of oblique incidence. As before, we consider two cases

- i. When the second medium is a perfect conductor.
- ii. When the second medium is a perfect dielectric.

A plane incidence is defined as the plane containing the vector indicating the direction of propagation of the incident wave and normal to the interface. We study two specific cases when the incident electric field  $\vec{E}_i$  is perpendicular to the plane of incidence (perpendicular polarization) and  $\vec{E}_i$  is parallel to the plane of incidence (parallel polarization). For a general case, the incident wave may have arbitrary polarization but the same can be expressed as a linear combination of these two individual cases.

### Oblique Incidence at a plane conducting boundary

- i. **Perpendicular Polarization**

The situation is depicted in figure 6.10.

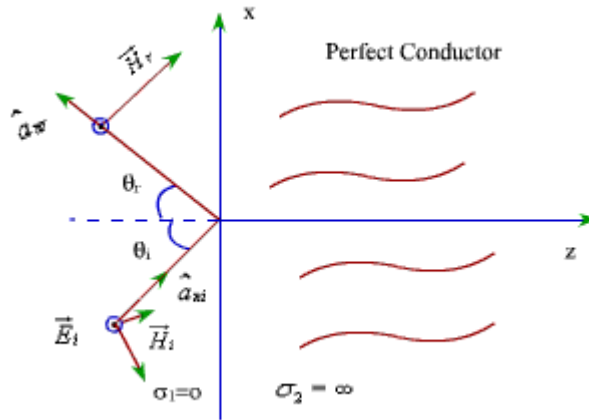

**Figure 6.10: Perpendicular Polarization**

As the EM field inside the perfect conductor is zero, the interface reflects the incident plane wave.  $\hat{a}_{ni}$  and  $\hat{a}_{nr}$  respectively represent the unit vector in the direction of propagation of the incident and reflected waves,  $\theta_i$  is the angle of incidence and  $\theta_r$  is the angle of reflection.

We find that

$$\begin{aligned} \hat{a}_{ni} &= \hat{a}_z \cos \theta_i + \hat{a}_x \sin \theta_i \\ \hat{a}_{nr} &= -\hat{a}_z \cos \theta_r + \hat{a}_x \sin \theta_r \end{aligned} \dots\dots\dots(6.69)$$

Since the incident wave is considered to be perpendicular to the plane of incidence, which for the present case happens to be xz plane, the electric field has only y-component.

Therefore,

$$\begin{aligned} \vec{E}_i(x, z) &= \hat{a}_y E_{i0} e^{-j\beta_1 \hat{a}_n \cdot \vec{r}} \\ &= \hat{a}_y E_{i0} e^{-j\beta_1(x \sin \theta_i + z \cos \theta_i)} \end{aligned}$$

The corresponding magnetic field is given by

$$\begin{aligned} \vec{H}_i(x, z) &= \frac{1}{n_1} [\hat{a}_n \times \vec{E}_i(x, z)] \\ &= \frac{1}{n_1} [-\cos \theta_i \hat{a}_x + \sin \theta_i \hat{a}_z] E_{i0} e^{-j\beta_1(x \sin \theta_i + z \cos \theta_i)} \end{aligned} \dots\dots\dots(6.70)$$

Similarly, we can write the reflected waves as

$$\begin{aligned}\vec{E}_r(x, z) &= \hat{a}_y E_{r0} e^{-j\beta_1 \bar{a}_n \cdot \vec{r}} \\ &= \hat{a}_y E_{r0} e^{-j\beta_1(x \sin \theta_r - z \cos \theta_r)}\end{aligned}\quad \dots\dots\dots(6.71)$$

Since at the interface  $z=0$ , the tangential electric field is zero.

$$E_{i0} e^{-j\beta_1 x \sin \theta_i} + E_{r0} e^{-j\beta_1 x \sin \theta_r} = 0 \quad \dots\dots\dots(6.72)$$

Consider in equation (6.72) is satisfied if we have

$$\begin{aligned}E_{r0} &= -E_{i0} \\ \text{and } \theta_i &= \theta_r\end{aligned}\quad \dots\dots\dots(6.73)$$

The condition  $\theta_i = \theta_r$  is Snell's law of reflection.

$$\therefore \vec{E}_r(x, z) = -\hat{a}_y E_{i0} e^{-j\beta_1(x \sin \theta_i - z \cos \theta_i)} \quad \dots\dots\dots(6.74)$$

$$\begin{aligned}\text{and } \vec{H}_r(x, z) &= \frac{1}{n_1} \left[ \hat{a}_{nr} \times \vec{E}_r(x, z) \right] \\ &= \frac{E_{i0}}{n_1} \left[ -\hat{a}_x \cos \theta_i - \hat{a}_z \sin \theta_i \right] e^{-j\beta_1(x \sin \theta_i - z \cos \theta_i)}\end{aligned}\quad \dots\dots\dots(6.75)$$

The total electric field is given by

$$\begin{aligned}\vec{E}_1(x, z) &= \vec{E}_i(x, z) + \vec{E}_r(x, z) \\ &= -\hat{a}_y 2j E_{i0} \sin(\beta_1 z \cos \theta_i) e^{-j\beta_1 x \sin \theta_i}\end{aligned}\quad \dots\dots\dots(6.76)$$

Similarly, total magnetic field is given by

$$\vec{H}_1(x, z) = -2 \frac{E_{i0}}{n_1} \left[ \hat{a}_x \cos \theta_i \cos(\beta_1 z \cos \theta_i) e^{-j\beta_1 x \sin \theta_i} + \hat{a}_z j \sin \theta_i \sin(\beta_1 z \cos \theta_i) e^{-j\beta_1 x \sin \theta_i} \right] \quad \dots\dots\dots(6.77)$$

From eqns (6.76) and (6.77) we observe that

1. Along  $z$  direction i.e. normal to the boundary  $y$  component of  $\vec{E}$  and  $x$  component of  $\vec{H}$  maintain standing wave patterns according to  $\sin \beta_{1z} z$  and  $\cos \beta_{1z} z$  where  $\beta_{1z} = \beta_1 \cos \theta_i$ . No average power propagates along  $z$  as  $y$  component of  $\vec{E}$  and  $x$  component of  $\vec{H}$  are out of phase.

2. Along x i.e. parallel to the interface  
 y component of  $\vec{E}$  and z component of  $\vec{H}$  are in phase (both time and space) and propagate with phase velocity

$$v_{p1x} = \frac{\omega}{\beta_{1x}} = \frac{\omega}{\beta_1 \sin \theta_i}$$

and  $\lambda_{1x} = \frac{2\pi}{\beta_{1x}} = \frac{\lambda_1}{\sin \theta_i}$  .....(6.78)

The wave propagating along the x direction has its amplitude varying with z and hence constitutes a **non uniform** plane wave. Further, only electric field  $\vec{E}_1$  is perpendicular to the direction of propagation (i.e. x), the magnetic field has component along the direction of propagation. Such waves are called transverse electric or TE waves.

**ii. Parallel Polarization:**

In this case also  $\hat{a}_{xi}$  and  $\hat{a}_{xr}$  are given by equations (6.69). Here  $\vec{H}_i$  and  $\vec{H}_r$  have only y component.

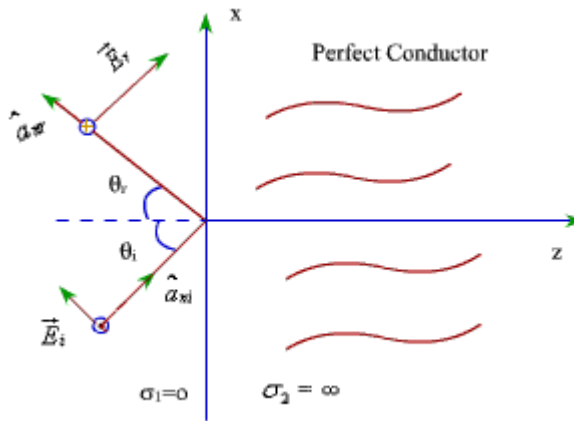

**Figure 6.11: Parallel Polarization**

With reference to fig (6.11), the field components can be written as:

Incident field components:

$$\vec{E}_i(x, z) = E_{io} \left[ \cos \theta_i \hat{a}_x - \sin \theta_i \hat{a}_z \right] e^{-j\beta_1(x \sin \theta_i + z \cos \theta_i)}$$

$$\vec{H}_i(x, z) = \hat{a}_y \frac{E_{io}}{n_1} e^{-j\beta_1(x \sin \theta_i + z \cos \theta_i)}$$

.....(6.79)

Reflected field components:

$$\begin{aligned} \vec{E}_r(x, z) &= E_{r0} \left[ \hat{a}_x \cos \theta_r + \hat{a}_z \sin \theta_r \right] e^{-j\beta_1(x \sin \theta_r - z \cos \theta_r)} \\ \vec{H}_r(x, z) &= -\hat{a}_y \frac{E_{r0}}{n_1} e^{-j\beta_1(x \sin \theta_r - z \cos \theta_r)} \end{aligned} \dots\dots\dots(6.80)$$

Since the total tangential electric field component at the interface is zero.

$$E_i(x, 0) + E_r(x, 0) = 0$$

Which leads to  $E_{r0} = -E_{i0}$  and  $\theta_r = \theta_i$  as before.

Substituting these quantities in (6.79) and adding the incident and reflected electric and magnetic field components the total electric and magnetic fields can be written as

$$\begin{aligned} \vec{E}_i(x, z) &= -2E_{i0} \left[ \hat{a}_x j \cos \theta_i \sin(\beta_1 z \cos \theta_i) + \hat{a}_z \sin \theta_i \cos(\beta_1 z \cos \theta_i) \right] e^{-j\beta_1 x \sin \theta_i} \\ \text{and } \vec{H}_i(x, z) &= \hat{a}_y \frac{2E_{i0}}{n_1} \cos(\beta_1 z \cos \theta_i) e^{-j\beta_1 x \sin \theta_i} \end{aligned} \dots\dots\dots(6.81)$$

Once again, we find a standing wave pattern along z for the x and y components of  $\vec{E}$  and  $\vec{H}$ , while a non uniform plane wave propagates along x with a phase velocity given by

$$v_{p1x} = \frac{v_{p1}}{\sin \theta_i} \text{ where } v_{p1} = \frac{\omega}{\beta_1}. \text{ Since, for this propagating wave, magnetic field is in transverse direction, such waves are called transverse magnetic or TM waves.}$$

**Oblique incidence at a plane dielectric interface**

We continue our discussion on the behavior of plane waves at an interface; this time we consider a plane dielectric interface. As earlier, we consider the two specific cases, namely parallel and perpendicular polarization.

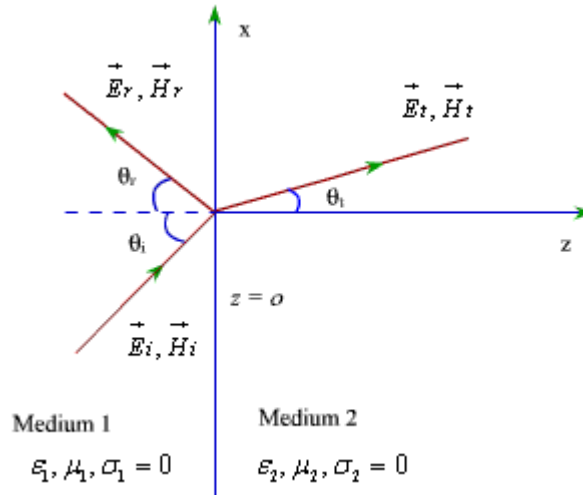

**Fig 6.12: Oblique incidence at a plane dielectric interface**

For the case of a plane dielectric interface, an incident wave will be reflected partially and transmitted partially.

In Fig(6.12),  $\theta_i, \theta_r$  and  $\theta_t$  corresponds respectively to the angle of incidence, reflection and transmission.

**1. Parallel Polarization**

As discussed previously, the incident and reflected field components can be written as

$$\begin{aligned} \vec{E}_i(x, z) &= E_{i0} \left[ \cos \theta_i \hat{a}_x - \sin \theta_i \hat{a}_z \right] e^{-j\beta_1(x \sin \theta_i + z \cos \theta_i)} \\ \vec{H}_i(x, z) &= \hat{a}_y \frac{E_{i0}}{n_1} e^{-j\beta_1(x \sin \theta_i + z \cos \theta_i)} \end{aligned} \dots\dots\dots(6.82)$$

$$\begin{aligned} \vec{E}_r(x, z) &= E_{r0} \left[ \hat{a}_x \cos \theta_r + \hat{a}_z \sin \theta_r \right] e^{-j\beta_1(x \sin \theta_r - z \cos \theta_r)} \\ \vec{H}_r(x, z) &= -\hat{a}_y \frac{E_{r0}}{n_1} e^{-j\beta_1(x \sin \theta_r - z \cos \theta_r)} \end{aligned} \dots\dots\dots(6.83)$$

In terms of the reflection coefficient  $\Gamma$

$$\begin{aligned} \vec{E}_r(x, z) &= \Gamma E_{i0} \left[ \hat{a}_x \cos \theta_r + \hat{a}_z \sin \theta_r \right] e^{-j\beta_1(x \sin \theta_r - z \cos \theta_r)} \\ \vec{H}_r(x, z) &= -\hat{a}_y \frac{\Gamma E_{i0}}{n_1} e^{-j\beta_1(x \sin \theta_r - z \cos \theta_r)} \end{aligned} \dots\dots\dots(6.84)$$

The transmitted field can be written in terms of the transmission coefficient  $T$

$$\begin{aligned}\vec{E}_t(x, z) &= TE_{io} \left[ \hat{a}_x \cos \theta_i - \hat{a}_z \sin \theta_i \right] e^{-j\beta_2(x \sin \theta_i + z \cos \theta_i)} \\ \vec{H}_t(x, z) &= \hat{a}_y \frac{TE_{io}}{n_2} e^{-j\beta_2(x \sin \theta_i + z \cos \theta_i)}\end{aligned}\dots\dots\dots(6.85)$$

We can now enforce the continuity of tangential field components at the boundary i.e.  $z=0$

$$\begin{aligned}\cos \theta_i e^{-j\beta_1 x \sin \theta_i} + \Gamma \cos \theta_r e^{-j\beta_1 x \sin \theta_r} &= T \cos \theta_t e^{-j\beta_2 x \sin \theta_t} \\ \text{and } \frac{1}{n_1} e^{-j\beta_1 x \sin \theta_i} - \frac{\Gamma}{n_1} e^{-j\beta_1 x \sin \theta_r} &= \frac{T}{n_2} e^{-j\beta_2 x \sin \theta_t}\end{aligned}\dots\dots\dots(6.86)$$

If both  $E_x$  and  $H_y$  are to be continuous at  $z=0$  for all  $x$ , then from the phase matching we have

$$\beta_1 \sin \theta_i = \beta_1 \sin \theta_r = \beta_2 \sin \theta_t$$

$\therefore$  We find that

$$\begin{aligned}\theta_i &= \theta_r \\ \text{and } \beta_1 \sin \theta_i &= \beta_2 \sin \theta_t \dots\dots\dots(6.87)\end{aligned}$$

Further, from equations (6.86) and (6.87) we have

$$\begin{aligned}\cos \theta_i + \Gamma \cos \theta_i &= T \cos \theta_t \\ \text{and } \frac{1}{n_1} - \frac{\Gamma}{n_1} &= \frac{T}{n_2}\end{aligned}\dots\dots\dots(6.88)$$

$$\therefore \cos \theta_i (1 + \Gamma) = T \cos \theta_t$$

$$\text{and } \frac{1}{n_1} (1 - \Gamma) = \frac{T}{n_2}$$

$$\therefore T = \frac{n_2}{n_1} (1 - \Gamma)$$

$$\cos \theta_i (1 + \Gamma) = \frac{n_2}{n_1} (1 - \Gamma) \cos \theta_t$$

$$\therefore (n_1 \cos \theta_i + n_2 \cos \theta_t) \Gamma = n_2 \cos \theta_t - n_1 \cos \theta_i$$

$$\text{or } \Gamma = \frac{n_2 \cos \theta_i - n_1 \cos \theta_t}{n_2 \cos \theta_i + n_1 \cos \theta_t} \dots\dots\dots(6.89)$$

$$\begin{aligned} \text{and } T &= \frac{n_2}{n_1} (1 - \Gamma) \\ &= \frac{2n_2 \cos \theta_i}{n_2 \cos \theta_i + n_1 \cos \theta_t} \dots\dots\dots(6.90) \end{aligned}$$

From equation (6.90) we find that there exists specific angle  $\theta_i = \theta_b$  for which  $\Gamma = 0$  such that

$$n_2 \cos \theta_i = n_1 \cos \theta_b$$

$$\text{or } \sqrt{1 - \sin^2 \theta_i} = \frac{n_1}{n_2} \sqrt{1 - \sin^2 \theta_b} \dots\dots\dots(6.91)$$

$$\sin \theta_i = \frac{\beta_1}{\beta_2} \sin \theta_b \dots\dots\dots(6.92)$$

Further,

For non magnetic material  $\mu_1 = \mu_2 = \mu_0$

Using this condition

$$\begin{aligned} 1 - \sin^2 \theta_i &= \frac{\epsilon_1}{\epsilon_2} (1 - \sin^2 \theta_b) \\ \text{and } \sin^2 \theta_i &= \frac{\epsilon_1}{\epsilon_2} \sin^2 \theta_b \dots\dots\dots(6.93) \end{aligned}$$

From equation (6.93), solving for  $\sin \theta_b$  we get

$$\sin \theta_b = \frac{1}{\sqrt{1 + \frac{\epsilon_1}{\epsilon_2}}}$$

This angle of incidence for which  $\Gamma = 0$  is called Brewster angle. Since we are dealing with parallel polarization we represent this angle by  $\theta_{b\parallel}$  so that

$$\sin \theta_{b\parallel} = \frac{1}{\sqrt{1 + \frac{\epsilon_1}{\epsilon_2}}}$$



## 2. Perpendicular Polarization

For this case

$$\begin{aligned}\vec{E}_i(x, z) &= \hat{a}_y E_{i0} e^{-j\beta_1(x\sin\theta_i + z\cos\theta_i)} \\ \vec{H}_i(x, z) &= \frac{E_{i0}}{n_1} \left[ -\hat{a}_x \cos\theta_i + \hat{a}_z \sin\theta_i \right] e^{-j\beta_1(x\sin\theta_i + z\cos\theta_i)}\end{aligned}\quad \dots\dots\dots(6.94)$$

$$\begin{aligned}\vec{E}_r(x, z) &= \hat{a}_y \Gamma E_{i0} e^{-j\beta_1(x\sin\theta_r - z\cos\theta_r)} \\ \vec{H}_r(x, z) &= \frac{\Gamma E_{i0}}{n_1} \left[ \hat{a}_x \cos\theta_r + \hat{a}_z \sin\theta_r \right] e^{-j\beta_1(x\sin\theta_r - z\cos\theta_r)}\end{aligned}\quad \dots\dots\dots(6.95)$$

$$\begin{aligned}\vec{E}_t(x, z) &= \hat{a}_y T E_{i0} e^{-j\beta_2(x\sin\theta_t + z\cos\theta_t)} \\ \vec{H}_t(x, z) &= \frac{T E_{i0}}{n_2} \left[ -\hat{a}_x \cos\theta_t + \hat{a}_z \sin\theta_t \right] e^{-j\beta_2(x\sin\theta_t + z\cos\theta_t)}\end{aligned}\quad \dots\dots\dots(6.96)$$

Using continuity of field components at  $z=0$

$$\begin{aligned}e^{-j\beta_1 x \sin\theta_i} + \Gamma e^{-j\beta_1 x \sin\theta_r} &= T e^{-j\beta_2 x \sin\theta_t} \\ \text{and } -\frac{1}{n_1} \cos\theta_i e^{-j\beta_1 x \sin\theta_i} + \frac{\Gamma}{n_1} \cos\theta_r e^{-j\beta_1 x \sin\theta_r} &= -\frac{T}{n_2} \cos\theta_t e^{-j\beta_2 x \sin\theta_t}\end{aligned}\quad \dots\dots\dots(6.97)$$

As in the previous case

$$\begin{aligned}\beta_1 \sin\theta_i &= \beta_1 \sin\theta_r = \beta_2 \sin\theta_t \\ \therefore \theta_i &= \theta_r \\ \text{and } \sin\theta_r &= \frac{\beta_1}{\beta_2} \sin\theta_i\end{aligned}\quad \dots\dots\dots(6.98)$$

Using these conditions we can write

$$\begin{aligned}1 + \Gamma &= T \\ -\frac{\cos\theta_i}{n_1} + \frac{\Gamma \cos\theta_i}{n_1} &= -\frac{T \cos\theta_t}{n_2}\end{aligned}\quad \dots\dots\dots(6.99)$$

From equation (6.99) the reflection and transmission coefficients for the perpendicular polarization can be computed as

$$\Gamma = \frac{n_2 \cos \theta_i - n_1 \cos \theta_t}{n_2 \cos \theta_i + n_1 \cos \theta_t}$$

and  $T = \frac{2n_2 \cos \theta_i}{n_2 \cos \theta_i + n_1 \cos \theta_t} \dots\dots\dots(6.100)$

We observe that if  $\Gamma = 0$  for an angle of incidence  $\theta_i = \theta_b$

$$n_2 \cos \theta_b = n_1 \cos \theta_t$$

$$\begin{aligned} \therefore \cos^2 \theta_t &= \frac{n_2}{n_1} \cos^2 \theta_b \\ &= \frac{\mu_2 \epsilon_1}{\mu_1 \epsilon_2} \cos^2 \theta_b \end{aligned}$$

$$\therefore 1 - \sin^2 \theta_t = \frac{\mu_2 \epsilon_1}{\mu_1 \epsilon_2} (1 - \sin^2 \theta_b)$$

$$\sin \theta_t = \frac{\beta_1}{\beta_2} \sin \theta_b$$

Again

$$\therefore \sin^2 \theta_t = \frac{\mu_1 \epsilon_1}{\mu_2 \epsilon_2} \sin^2 \theta_b$$

$$\therefore \left( 1 - \frac{\mu_1 \epsilon_1}{\mu_2 \epsilon_2} \sin^2 \theta_b \right) = \frac{\mu_2 \epsilon_1}{\mu_1 \epsilon_2} - \frac{\mu_2 \epsilon_1}{\mu_1 \epsilon_2} \sin^2 \theta_b$$

$$\text{or } \sin^2 \theta_b \left( \frac{\mu_1 \epsilon_1}{\mu_2 \epsilon_2} - \frac{\mu_2 \epsilon_1}{\mu_1 \epsilon_2} \right) = \left( 1 - \frac{\mu_2 \epsilon_1}{\mu_1 \epsilon_2} \right)$$

$$\text{or } \sin^2 \theta_b \left( \frac{\mu_1^2 - \mu_2^2}{\mu_1 \mu_2 \epsilon_2} \right) \epsilon_1 = \left( \frac{\mu_1 \epsilon_2 - \mu_2 \epsilon_1}{\mu_1 \epsilon_2} \right)$$

$$\text{or } \sin^2 \theta_b = \frac{\mu_2 (\mu_1 \epsilon_2 - \mu_2 \epsilon_1)}{\epsilon_1 (\mu_1^2 - \mu_2^2)} \dots\dots\dots(6.101)$$

We observe if  $\mu_1 = \mu_2 = \mu_0$  i.e. in this case of non magnetic material Brewster angle does not exist as the denominator of equation (6.101) becomes zero. Thus for perpendicular polarization in dielectric media, there is Brewster angle so that  $\Gamma$  can be made equal to zero.

From our previous discussion we observe that for both polarizations

$$\sin \theta_t = \frac{\beta_1}{\beta_2} \sin \theta_i$$

If  $\mu_1 = \mu_2 = \mu_0$

$$\sin \theta_t = \sqrt{\frac{\epsilon_1}{\epsilon_2}} \sin \theta_i$$

For  $\epsilon_1 > \epsilon_2$ ;  $\theta_t > \theta_i$

The incidence angle  $\theta_i = \theta_c$  for which  $\theta_t = \frac{\pi}{2}$  i.e.  $\theta_c = \sin^{-1} \sqrt{\frac{\epsilon_2}{\epsilon_1}}$  is called the critical angle of incidence. If the angle of incidence is larger than  $\theta_c$  total internal reflection occurs. For such case an evanescent wave exists along the interface in the x direction (w.r.t. fig (6.12)) that attenuates exponentially in the normal i.e. z direction. Such waves are tightly bound to the interface and are called surface waves.